

SIRUBA

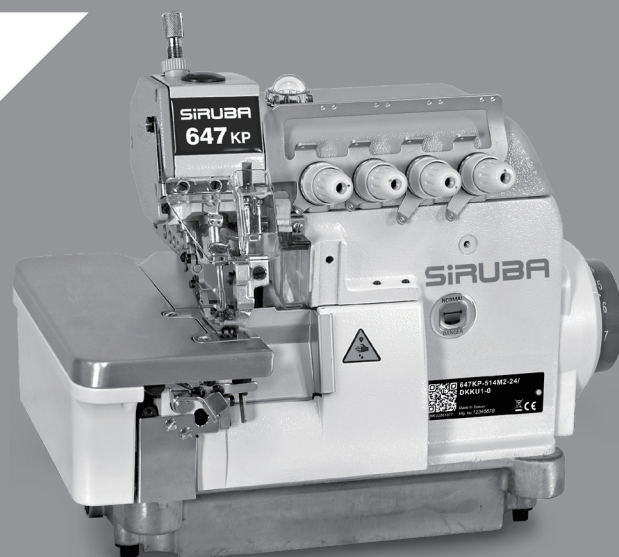

使用説明書

INSTRUCTION BOOK

■ 600KP



危險水準的說明 Explanation of Dangerous Level

 危險 Dangerous	<p>如果忽視此標記而運行了錯誤的機械操作，保養時肯定會引起當事者或第三者人員重傷或死亡。</p> <p>Don't ignore the warning sign and don't proceed incorrect operation. Or it will cause the person or the third party seriously injured or dead during maintenance.</p>
 注意 Caution	<p>如果忽視此標記而運行了錯誤的機械操作，保養時有可能會引起當事者或第三者人員受傷及造成設備損壞。</p> <p>Ignoring this warning sign and proceed incorrect operation will cause the person involved or the third party wounded and equipment damaged during maintenance.</p>

警告圖案表示及表示標誌的說明 Explanation of Warning Signs and Labels

警告圖案表示 Warning Sign		運動部位，謹防工傷事故 Moving part, beware of industrial accident
		高壓部位，謹防觸電事故 High voltage, beware of electric shock
		高溫部位，謹防燙傷事故 High temperature, beware of burns
指示標幟 Instruction Label		禁止 Prohibited
		地線的接線表示 Indication of ground wiring

索引	INDEX	頁 /PAGE
一般安全事項說明	GENERAL SAFETY INSTRUCTIONS	1
重要安全事項說明	IMPORTANT SAFETY INSTRUCTIONS	3
特別事項	WARNING	7
警告標籤	WARNING TAG	8
搬運縫紉機	MOVING THE SEWING MACHINE	9
縫紉機的安裝位置	THE INSTALLATION POSITION OF THE SEWING MACHINE	9
規格	SPECIFICATIONS	10
安裝	INSTALLATION	12
照明設備	LIGHTENING EQUIPMENT	15
新機器啟用規定	HOW TO OPERATE THE NEW MACHINE	16
潤滑油之注入與更換	LUBRICATION AND DRAINAGE	16
穿線方式	THREADING THE MACHINE	18
控線調整	ADJUST THREAD TENSION	19
換針方式	REPLACE THE NEEDLE	22
針距調整	ADJUST THE STITCH LENGTH	22
差動比調整	ADJUST THE DIFFERENTIAL FEED RATIO	23
更換切刀	REPLACE THE TRIMMERS	24
包邊寬度調整	ADJUST THE HEM WIDTH	25
針高度之調整	ADJUST THE NEEDLE HEIGHT	26

索引	INDEX	頁 /PAGE
押具調整	ADJUST THE PRESSER FOOT	26
送具調整	ADJUST THE FEED DOG	28
針與勾針之關係	THE RELATIONSHIP BETWEEN NEEDLE AND LOOPER	30
環勾針運動之調整	ADJUST THE CHAINSTITCH LOOPER MOVEMENT AMOUNT	32
保養	MAINTENANCE	33
報廢流程	DEMOLITION PROCEDURE	34

MODEL		600KP	
Net Weight(Kg)	27	Noise Level, dB(A)	82dB(A)
Serial No.		Vibration (m/sec ²)	
Dimension	Length	Width	Height
	35cm	22cm	31cm

一般安全事項說明

GENERAL SAFETY INSTRUCTIONS

警告！

當使用這台機器，基本安全預防應恆被遵守，以減輕火災、電擊、或是個人傷害的風險。包含以下注意事項。
在操作這台機器之前，請閱讀所有說明並且緊記於心。

- 1. 保持工作場所清潔**
雜亂的環境與椅子會招引危害。
- 2. 考量工作場所環境**
勿暴露電源於雨水之中、勿在溼氣重的地方或潮濕的場所使用機械器具。保持工作場所良好整齊。當有引發火災或爆炸危險時，勿使用電源工具。
- 3. 免於電擊危害**
避免身體接觸地線或是接地表面。(即：管線，發熱物體，以及冷凍庫)
- 4. 勿使孩童接近**
不要讓訪客接觸工具或是延伸管線。
- 5. 適當的穿著**
不要穿著寬鬆衣物或是穿戴珠寶，這可能被活動零件拉扯而導致危險。穿戴護髮套可包住長髮。
- 6. 不要任意拉扯電線**
絕不要用電源端拉扯機器，或是從插座猛拉電線來拔掉電線。使電線遠離熱源、油類或是尖銳邊緣。
- 7. 謹慎保養機器**
遵從指示來添加潤滑油或是更換附件。定期檢測工具用線，如果有所損害，請使用合格的維修器具來修復。

Warning!

When using this machine, basic safety Precautions should always be followed to reduce the risk of fire, electric shock and personal injury, including the followings. Read all these instructions before operating this product and save these instructions.

- 1. Keep work area clean**
Cluttered areas and benches invite injuries.
- 2. Consider work area environment**
Do not expose power to rain. Do not use machine tools in damp or wet locations. Keep work area well lit.
Do not use power tools where there is risk to cause any fire or explosion.
- 3. Guard against electric shock**
Avoid body contact with earthed or grounded surfaces (e.g. Pipes, radiators, ranges refrigerators.)
- 4. Keep children away**
Do not let visitors touch the tool or extension code.
- 5. Dress properly**
Do not wear loose clothing or jewelry, they can be caught in moving parts. Wear protecting hair covering to contain long hair.
- 6. Do not abuse the cord**
Never carry the machine by cord or yank it to disconnect it from the socket. Keep the cord away from heat, oil, and sharp edges..
- 7. Maintain machine with care**
Follow instructions for lubrication and changing accessories. Inspect tool cord periodically. If damaged, have it repaired by an authorized service facility.

8. 中斷機器電源

當不使用機器時、維修前、以及更換配件時。

9. 避免誤啟動

不要以手指置於啟動開關上之後，搬運一個已插入電源的工具。確定在插電之前，電源開關是關閉的。

10. 檢查損害零件

在進一步使用器具之前，應該小心檢查並確認損傷的零件或是穿戴保護器具來確認零件會正確運轉並且呈現應有功能。

11. 警告

除了在這本使用說明手冊中建議的功能之外，任何附件或是配件的使用，都可能會導致個人傷害的危險。

12. 由合格人員來修理器具

所以修理工作應由合格的人員使用原始個別零件來作修理。

連接電源的特別警示！

1. 只可與有 "CE" 認證的按壓啟動裝置連接這台機器。
2. 遵守此使用說明手冊來安裝控制裝置。
3. 在操作過程中，永遠保持機器適當的接地。
4. 在調整、更換零件、或是維修保養之前，必須確定將插頭由插座拔出，以預防任何機器意料之外的啟動而造成危害。

8. Disconnect machine

When not in use, before servicing and when changing accessories.

9. Avoid unintentional starting

Do not carry a plug-in tool with a finger on the switch. Ensure the power switch is off when plugging in.

10. Check damaged parts

Before further use of the tool, a guard or other part that is damaged should be carefully checked to determine that it will operate properly and perform its intended function.

11. Warning

The use of any accessory or attachment, other than those recommended in this instruction manual, may present a risk of personal injury.

12. Have your tool repaired by a qualified person







Repairs should only be carried out by qualified persons using original spare parts.

SPECIAL WARNING FOR ELECTRIC CONNECTION!

1. Incorporate this machine only with "CE" certificate hold-to-run control device.
2. Follow the instruction manual device to install control device.
3. Always earth machine appropriately during operation.
4. Before adjustment, parts change or servicing must be sure to pull out the plug from socket to prevent the hazard of unintentionally start of machine.





重要安全事項說明



恭喜您購買本機器，為了使這台機器能獲得最佳功能以及安全的操作，務必請正確的使用這台機器，使用前請仔細閱讀使用說明書，希望您能長期使用它。請記得將此說明書放在容易取得的地方。

-  1. 當您使用機器時，除了以下事項外，請注意其他基本安全措施。
-  2. 使用機器前，除了本使用說明書外，請詳細閱讀其他相關說明書。此外，請妥善保存此說明書，以便需要時可以隨時取閱。
-  3. 先確認機器是符合貴國安全規定及標準後，再使用機器。
-  4. 當機器完成操作時，所有安全配備必須安裝就緒，在缺少所述安全配備下操作是不被允許的，以免導致人員受傷。
-  5. 此機器應由受過適當訓練之操作員操作。
-  6. 為了安全，我們建議您配戴安全眼鏡。
-  7. 以下情形，請先關閉電源或拔掉插頭：
 - (1) 穿針線、導線片、天平等以及更換梭子時。
 - (2) 更換針、壓具、針板、送具、頂針片、車布導板，以及其他附屬配件時。
 - (3) 維修工作時。
 - (4) 離開工作場所或工作場所無人看顧時。

IMPORTANT SAFETY INSTRUCTION

For operating safely and getting the best functions of this machine, you must operate it correctly. Please read and follow the instructions of this manual, and keep it at hand for future references. We are confident that you will enjoy this machine as much as we enjoy manufacturing it.

-  1. Instead of the following instructions, when you use this machine, please pay attention to the basic safety measures.
-  2. Before using this machine, please read this manual and all related instructions. In addition, please keep this manual for future needs.
-  3. Before using this machine, please ascertain that it conforms with safety standards and regulations of your country.
-  4. When the machine is ready for operation, all the safety equipments must be ready. Operate this machine without the specified safety devices is not allowed.
-  5. This machine must be operated by a properly trained operator.
-  6. For your own safety, we suggest you wearing goggles.
-  7. Please turn off the power switch or disconnect it for any one of the circumstances of the followings:
 - (1) When threading needle(s), adjusting thread Take-up(s), thread guide(s), and/or replacing bobbin(s).
 - (2) When replacing needles, presser feet, needle plates, feed dogs, needle guards, cloth guides and other parts or accessories.
 - (3) When repairing.
 - (4) When the operator leaves the working place or leaves the machine unattended.

 8. 假如不慎讓機器及配件使用之油或油脂，接觸到眼睛、皮膚或誤食時，請立刻以水清洗接觸部位及就診。



 9. 請勿擅自碰觸運轉中之零件及配件及注意機器電源是否已開啟，以免導致人員受傷。

 10. 維修、修改及調整等工作，須由受過適當訓練的技師或熟手為之。維修時只許使用指定之零件。

 11. 一般維修及檢查工作必須由受過適當訓練的人員為之。

 12. 電子零件維修及保養工作必須由資深的電子技師為之，或由非常熟練的人員檢查及指導，當發現零件損壞時，請立刻停止機器運轉。

 13. 在做裝有氣動式零件（例如氣缸）機器的維修及保養工作前，機器連接空壓機及高壓空氣必須予以關閉及卸除，機器中殘存高壓氣體必須予以消除，此外調整及性能檢查只能由受過適當訓練的技師或熟手為之。

 14. 機器使用一段時間，必須定期清理。

 8. If grease, oil, or any fluid contacts your skin or eyes by any chance, please wash the contacted area completely with clean water and consult a doctor. Or, swallow any fluid mistakenly, consult a doctor immediately.

 9. Do not touch any functioning parts and devices. Always attend to whether power switch is on or off before operating in order to prevent anyone from getting hurts.

 10. Qualified technicians are required for adjustment, modification, and repair. Only use assigned parts for replacement.

 11. Routine maintenance and service must be performed by well trained persons, or qualified technicians.

 12. Maintain and check the electronic parts must be done by qualified electrician or well-trained persons. If any electronic part damaged or malfunctioned, stop the machine immediately.

 13. The air house has to be detached from the machine and the compressor or air supply has to be cut off before repairing and servicing the machine equipped with pneumatic parts such as an air cylinder. Qualified technicians or well-trained persons are required for adjustment and repairs.

 14. To ensure the best performance, periodically clean the machine is necessary.

 15. 為使機器能正常操作以及減少噪音，機台務必平放地上，機器避免在強烈噪音的環境下操作。

 16. 選用適當的電源插頭，並由電子技師將其安裝在機器上，且插頭必須插在接地線之插座上。

 17. 機器只允許被使用於指定用途上，其他用途是不允許的。

 18. 修改或變更機器必須依照安全規定及標準，同時採取有效的安全措施或變更機器所引起損壞之責。

 19. 警告提示以兩種符號標示：

(1) 對操作員或服務人員之傷害危險，也為了避免觸電之危險，請勿打開馬達電器箱之外蓋，也不要觸摸電器箱裡面之零件。

 (2) 必須特別注意事項
a. 絕對不可在移動外蓋，手指保護蓋或安全配件後，進行機器操作，以免導致人員受傷。

b. 為了避免被機器纏住，當機器運轉中，您的手、頭髮及衣服，需遠離手輪；此外這些部位周圍不可放置任何物品，以免導致人員受傷。

 15. In order to operate properly and to reduce the noise, please place the machine flat and level on the ground. Avoid operating the sewing machine at a noisy surrounding.

 16. Select a proper power plug and install it by an electrician. Please connect the power plug to a grounded receptacle.

 17. This machine can only be used for the designed purpose. Other uses of this machine are not allowed.

 18. Any modification or conversion made on this machine must be conformed with the safety standards and regulations. Precaution is necessary. No responsibility will our company take for damages caused by any modification or conversion of this machine without permission.

 19. Two safety warning signs are applied as warning signs:

(1) For the safety of operators and service persons, please don't open the cover of any electronic control boxes of motor or other devices and don't touch any components inside to avoid electrical shock hazards.

 (2) Always keep in mind:
a. Please never operate this machine without outer cover, finger guard or any safety device to avoid physical injury.

b. Please keep your hair, fingers and clothes away from the hand wheel while the machine is in operation, as well as never put anything near these parts, to prevent the risk of injuries by tangled into them.

 c. 當您打開電源開關後或機器已在運轉中，絕不可將您的手放在針的下方或針線控線桿外蓋中，以免導致人員受傷。

 d. 當機器運轉中，梭頭高速轉動，為了避免對手可能引起之傷害，必須確定您的手保持遠離梭頭附近。此外，當更換梭子時，確定電源開關已關閉，以免導致人員受傷。

 e. 當放置或抬起機器時，小心勿將手置於機器中，以免導致人員受傷。

 f. 為了避免機器突然啟動而引起可能意外，當機頭傾斜時，請關掉機器電源，以免導致人員受傷。

 g. 如果您的機器是配置伺服馬達，機器於靜止狀態時，馬達是不會產生噪音的，為了避免機器突然啟動而引起可能意外，故請關掉機器電源。

 h. 為了避免觸電之危險，請絕不要在移開電源接地線後操作機器。

 i. 為了避免觸電或電子零件損壞而引起之可能意外，請先切斷電源，再插上或拔掉插頭。

 c. Please never put your fingers under the needle(s) or in the thread take-up cover to prevent physical injuries when you turn on the power switch or operate the machine.

 d. While the machine is in operation, the hook rotates at a high speed. Please keep your hands away from the area of hook to prevent any potential injury to your hands. In addition, please make sure to turn off the power of the machine while changing bobbins.

 e. Be careful and do not place your fingers inside the machine when placing or lifting the machine head to avoid possible physical injuries.

 f. Please turn off the power before tilting the machine head to avoid possible accidents due to abrupt start of this machine.

 g. For machine equipped servo motors, the motors do not produce noise while the machines are at rest. Therefore, please turn off the power of this accidents due to abrupt start of the machine.

 h. Never operate the sewing machine after the ground wire is removed to avoid electrical shock hazards.

 i. Please turn the power switch off before connecting or disconnecting the power plug to prevent possible accidents due to electric shock or damaged electronic components.

特別事項

WARNING

為了避免機器故障及損壞，請先確定以下事項：







-  1. 當您安裝好機器後，做第一次機器操作前，請徹底清潔機器。
-  2. 清除運送途中累積之灰塵及溢出之油脂。
-  3. 確定電壓及馬達相數（單相或三相）安裝正確。
-  4. 確定電源插頭正確地接上電源。
-  5. 當使用電壓與標示電壓不同時，請勿使用機器。
-  6. 確定機器轉動方向是否正確。



警告：

在操作或調整本書中所提到之各步驟前，請先將電源關掉，以免因為機器突然啟動造成之意外。

Please confirm the followings to avoid malfunction or damage to this machine.

-  1. After installing the machine, and before the first operation, please clean it completely.
-  2. Clean all dust and overflowed oil during transportation.
-  3. Confirm that the voltage and the phase (single or 3 phase) of motor are set correctly.
-  4. Confirm that the power plug is correctly connected to the power supply.
-  5. Never use the machine when the local voltage type is different from the marked voltage on the nametag attached on the machine.
-  6. Confirm that the rotating direction of the machine pulley is correct.



Warning:

Before doing any operation or any adjustment described later in this manual, please turn the power off to prevent accidents caused by abrupt start of the sewing machine.

警告標籤

WARNING TAG

1. 縫紉機上有警告標籤 (圖 1)。
2. 當使用縫紉機時，請遵守標籤上的說明。
如果標籤脫落或模糊不清，請和購買商店聯繫。

1. The following warning tags will be attached on the sewing machine.(Fig. 1)
2. When using the sewing machine, please follow the instructions of the tags. please contact the dealer if any of the tags is fallen off or fuzzy.



圖 1 / Fig. 1

3. 安全防護裝置及 ↻ 轉動方向。(圖 2)

3. Safety protection device and ↻ rotary direction. (Fig.2)

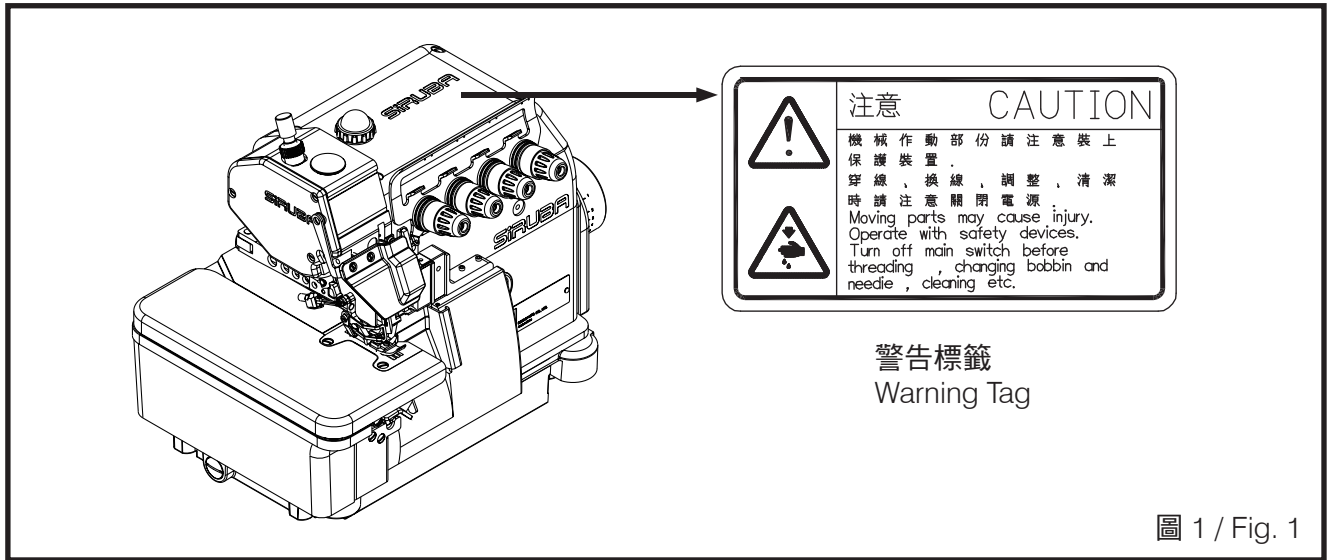

圖 2 / Fig. 2

搬運縫紉機

MOVING THE SEWING MACHINE

縫紉機之搬運(圖 3)

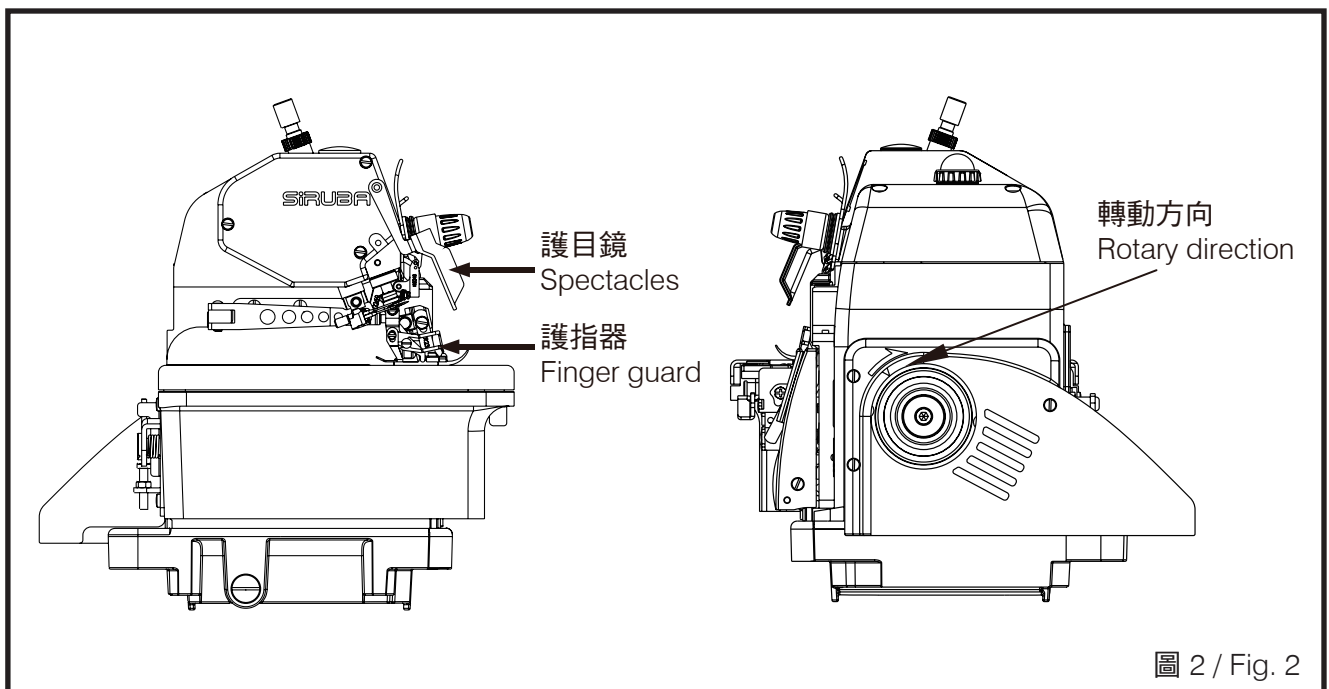
1. 應按圖示用左手托住前機殼本體，右手撐扶住底盤進行搬運。
2. 搬運時須穿著安全鞋。

Moving the sewing machine (Fig. 3)

1. To move the sewing machine, please follow the figure shows. Using left hand to hold the front machine cover body, and right hand to hold the bottom plate to move.
2. Please wear safety shoes while moving.



圖 3/ Fig. 3

縫紉機的安裝位置

THE INSTALLATION POSITION OF THE SEWING MACHINE

1. 勿將該縫紉機置於設備附近，如電視機、收音機或無線電話等，否則這些設備可能會對縫紉機的電子干擾所影響。(圖 4)

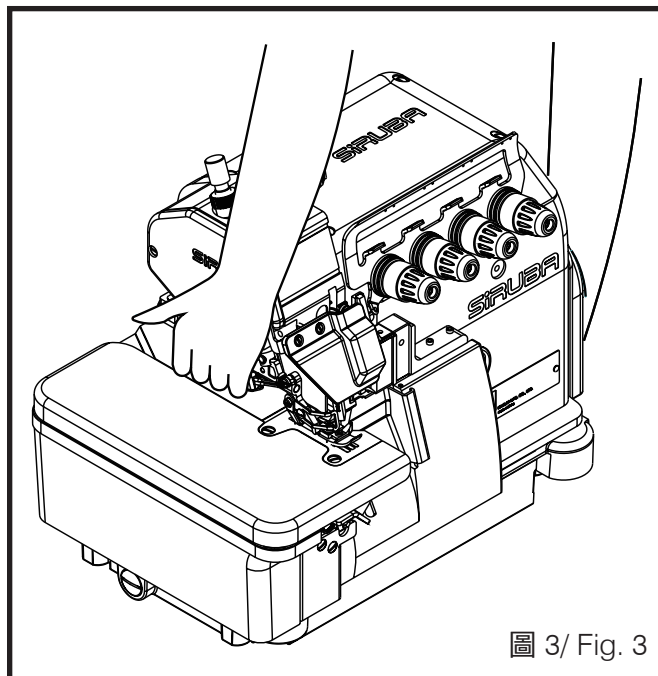
1. Please do not install the sewing machine near the equipments, such as Television, Radio, or Wireless Telephone. Or these equipments will experience electronic interference. (Fig. 4)



圖 4/ Fig. 4

2. 應將縫紉機直接插入 AC 電源插座，如果使用延長線，可能會造成操作故障。(圖 5)

2. The wire should insert the AC power socket directly. If using the extension wire, this might cause malfunction. (Fig.5)

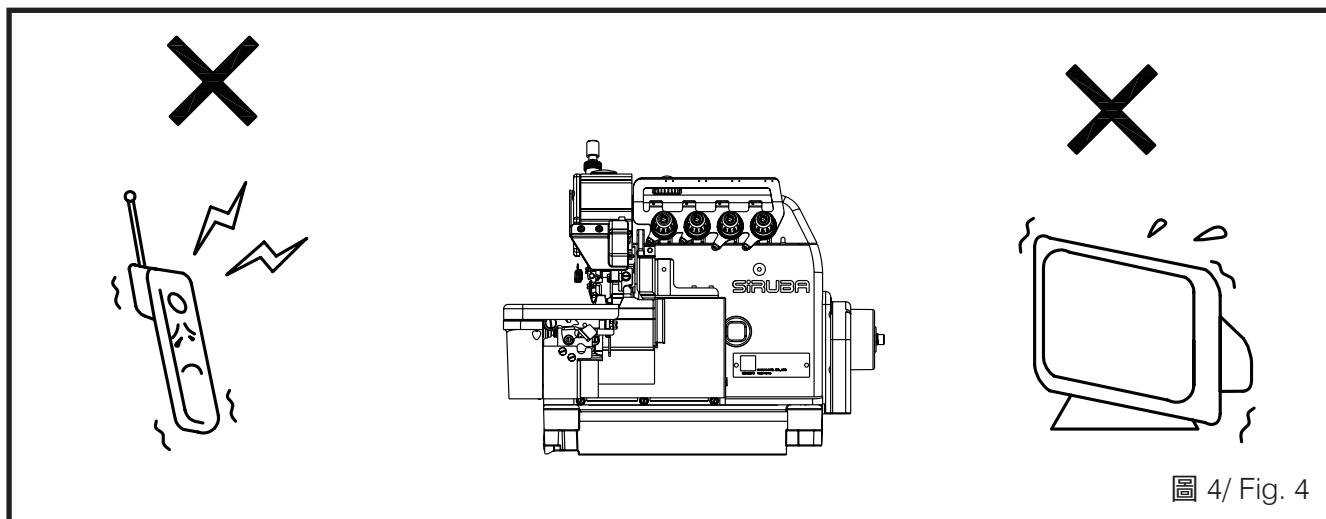

圖 5 / Fig. 5

規格

SPECIFICATIONS

1. 型號分類表示：

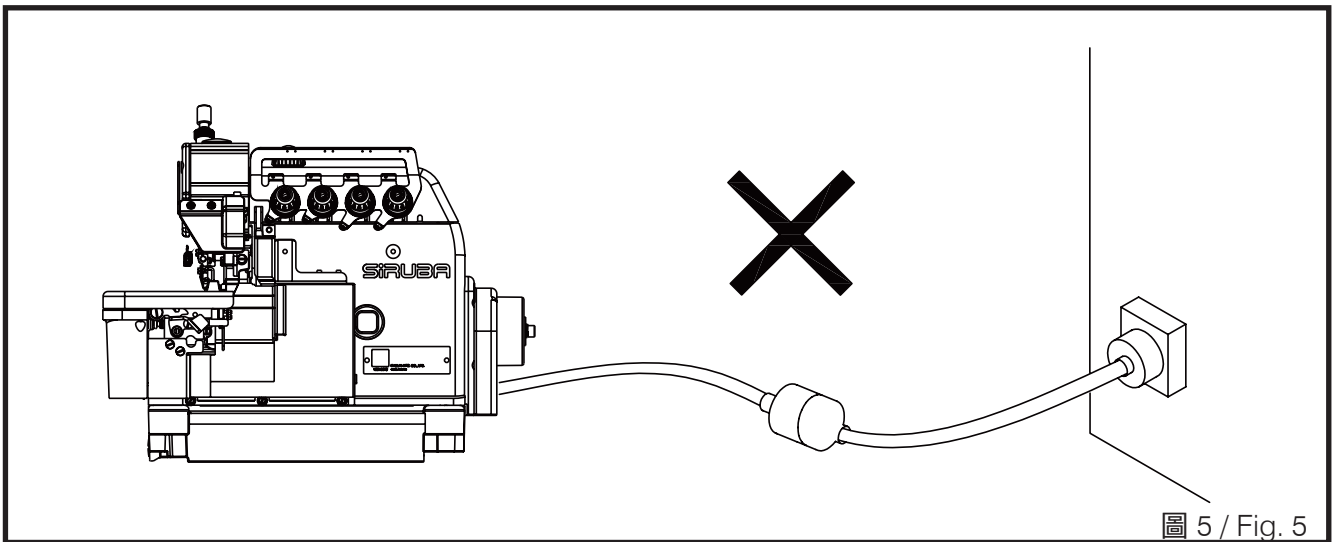
1. Description:

647 KP - 514 M - 2 - 2 4 VT

(1) (2) (3) (4) (5) (6) (7) (8)

(1) 表示線數分 637、647、657

(1) Thread numbers / Four types :
637、647、657

(2) 機種別

(2) Machine type

(3) 縫合方式 (圖表 1)

(3) Sewing type (Chart 1)

型式 Type	504	512	514	516
圖形 Pattern				

圖表 1 / Chart 1

(4) 車縫布料
M: 中厚布料
H: 厚布料

(4) Sewing materials
M: Medium weight material
H: Heavy weight material

(5) 送具型式

(5) Feed dog type

(6) 針寬

(6) Needle width

(7) 包邊寬度：4: 4mm, 5: 5mm

(7) Seam width: 4: 4mm, 5: 5mm

(8) 配件

(8) Attachment

2. 規格說明 (表 1)

2. Specification (Tab.1)

機型 Model	600KP
最高縫速 Max Stitch Speed	6500 spm
噪音值 Noise Level	82 分貝以下 under 82 dB
縫距 Stitch Length	4 / 5 / 6 mm
針棒行程 Stroke of the needle bar	標準行程 (Standard lift) 24.3 ±0.2 mm
押具揚程 Presser Foot Lift	5.5mm
押具壓力 Presser Foot Pressure	5kg
送具高度 (凸出針板面) Feed Dog Height (over the plate)	0.9~1.1mm
使用針 Needle for Use	DCX27
送具傳動方式 Feed Dog Transmission	偏心輪、連桿 Eccentric, Connecting Rod
送具齒寬度 Teeth Width of the Feed Dog	1.6mm
縫目調整裝置 Stitch Adjusting Device	按鈕調整 Button Adjustment
押具裝置 Presser Foot Device	彈簧式、旋鈕調整式 Spring Type, Knob Adjustment Type
加油方式 Oil Filling	儲油槽儲存方式，毛氈、棉線毛細管自動供油 Oil tank storage type. Automatic oil supply by Oil felt, otton thread capillary action.
回油方式 Oil Return Solution	偏心泵浦 Eccentric Pump
使用油 Oil for Use	提供專用油 (MOBIL #10) Provide Specific Oil (MOBIL #10)

表 1 / Tab. 1

安裝

INSTALLATION



注意CAUTION



請讓受過培訓的技術人員來安裝縫紉機。

Machine installation should only be carried out by a qualified technician.



請委託購買商店電氣專業人員進行電氣配線。

Contact your dealer or a qualified electrician for any electrical work that may need to be done.



縫紉機重30公斤, 安裝工作必須由兩人以上來完成。

The sewing machine weighs 30kg. The installation should be carried out by two or more people.



在安裝完成前, 請不要連接電源, 如果誤按啟動開關, 縫紉機動作會導致受傷。

Do not connect the power cord until installation is complete. The machine may operate if the treadle is depressed by mistake, which could result in injury.



縫紉機頭倒下豎起時, 請用雙手進行操作。單手操作時因縫紉機的重量萬一滑落易導致受傷。

Use both hands to hold the machine head when tilting it back or returning it to its original position. If only using one hand, the weight of the machine head may be too heavy to hold, and may cause human physical injuries.

1. 縫紉機拆箱搬運過程中, 不可扶持布板蓋
①。(圖 6)

1. While moving the sewing machine, please do not hold the below side of the cloth cover ①.(Fig. 6)



圖 6 / Fig. 6

2. 依本機所附桌板裁製圖及零件組合圖所列之配件，依序安裝防震機座鋁板①。(圖 7)

2. Please refer to the attached table cut-out diagram and the parts list to assemble the anti-chock machine aluminum plate ① in order. (Fig.7)

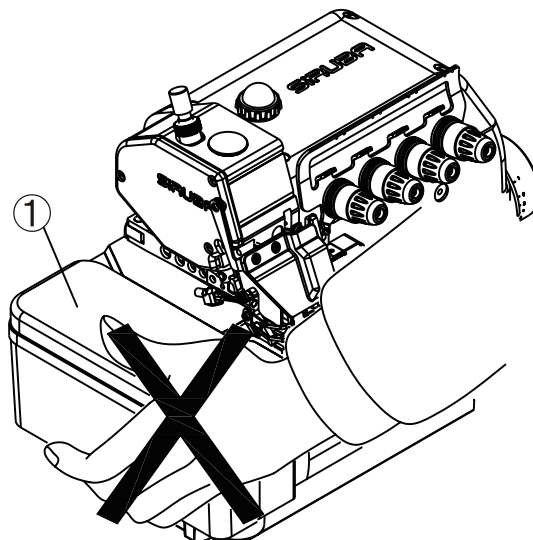
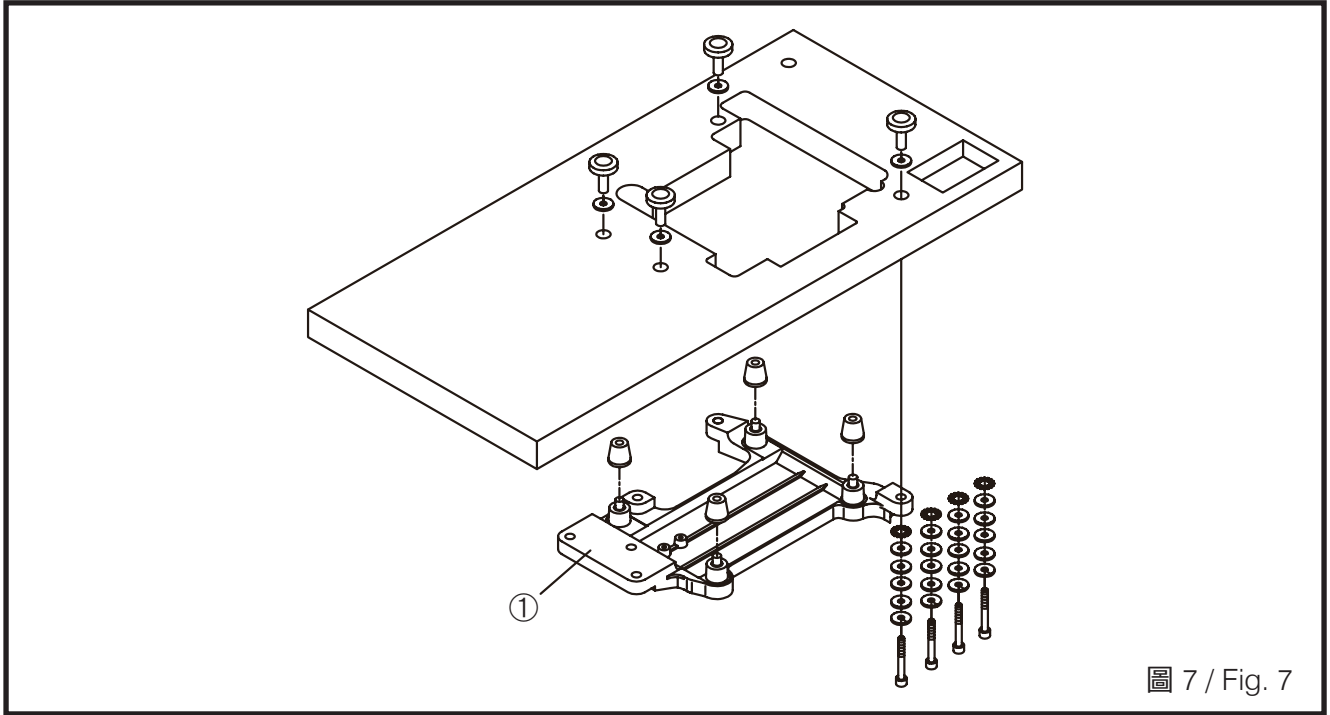

3. 裝置導布屑及線架。(圖 8)

3. Assemble the waste disposal set and the thread stand. (Fig.8)

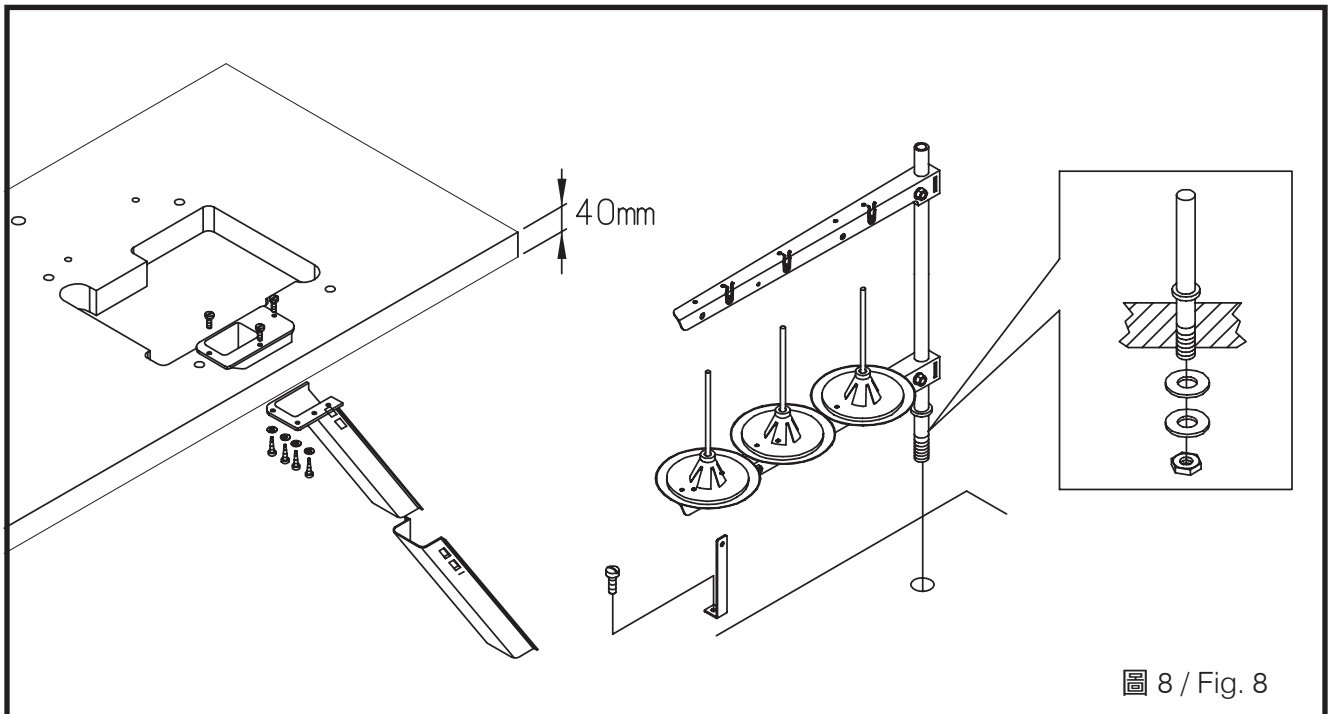

4. 馬達啟動踏板①裝於左邊， 押具腳踏板②則裝於右邊。(圖 9)

4. Install the motor activating plate ① to the left, and the presser pedal ② to the right. (Fig.9)

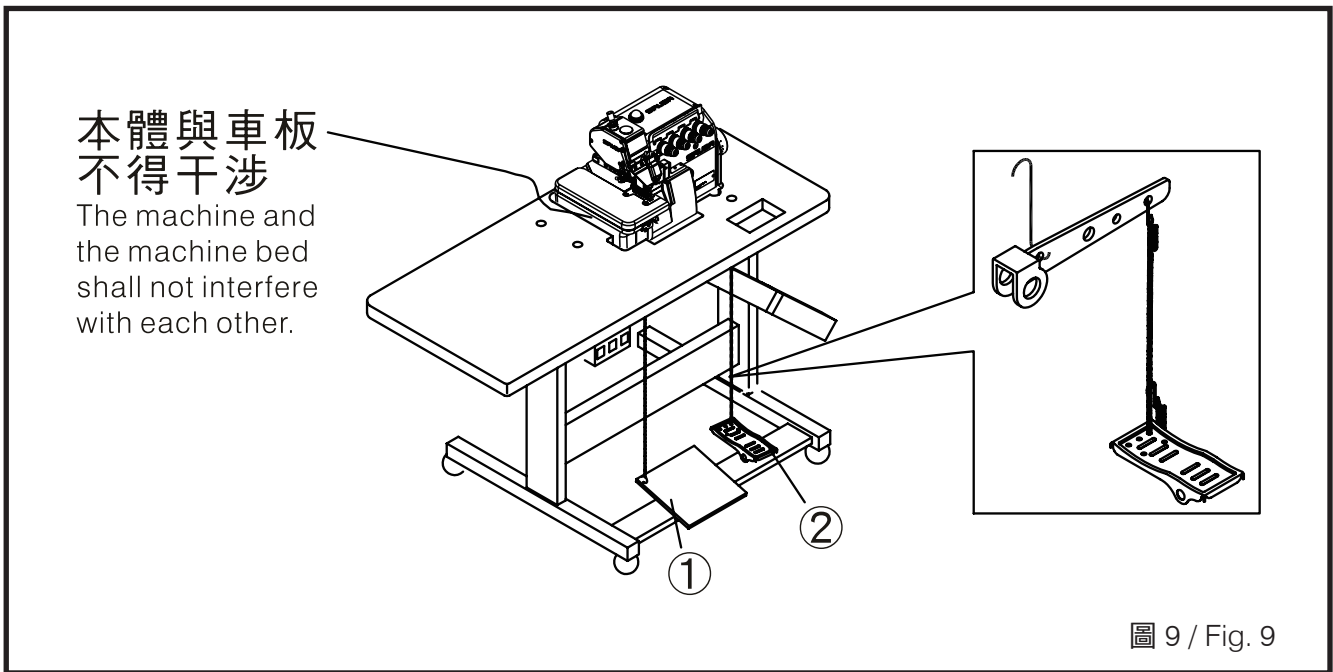

5. 注意馬達之轉向為順時鐘方向，皮帶①之鬆緊度以用手指向內壓下縮10 mm之緊度為宜。皮帶輪②大小與車縫轉速請參照表3及圖13。

5. Please be noted that the turning direction of the motor is clockwise. The best tension of the motor belt ① is that the belt can be pressed in about 10 mm by a finger. Please refer to Table 3 and Fig. 13 about the size of the pulley ② and the sewing speed.

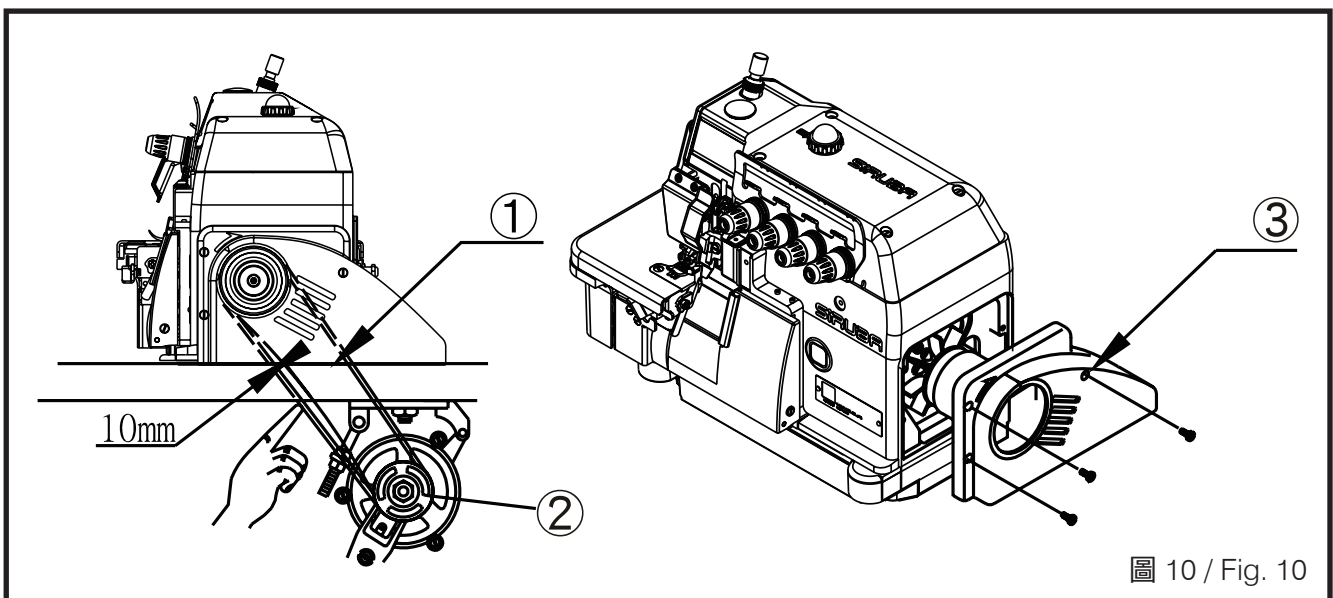

Machine (S.P.M)	Motor pulley Diameter(mm)	
	60Hz	50Hz
6,000	95	115
6,500	105	125

表 2 / Tab. 2

6. 確保使用者的安全，一定要鎖上皮帶護蓋
③。

6. To ensure the safety of the operators,
please tighten the belt protection cover ③
tightly.

照明設備

LIGHTENING EQUIPMENT

貼心使用者設計的照明機構，其採用不發熱、
壽命長之發光二極體 LED 燈具，讓使用者能方
便於穿線。(圖 11)

Thoughtful lightening equipment is deigned for
the operators. Non-heating and long life LED
lamps are adopted so that the operators can
thread easily.(Fig.11)



圖 11 / Fig. 11

新機器啟用規定

1. 新機器在最初啟用磨合期的四個星期內，請用低於最高速度 20% 的速度運轉，之後換上新潤滑油，才運轉至最高速度。
2. 定期之清潔保養，確保延長機器之使用壽命。

HOW TO OPERATE THE NEW MACHINE

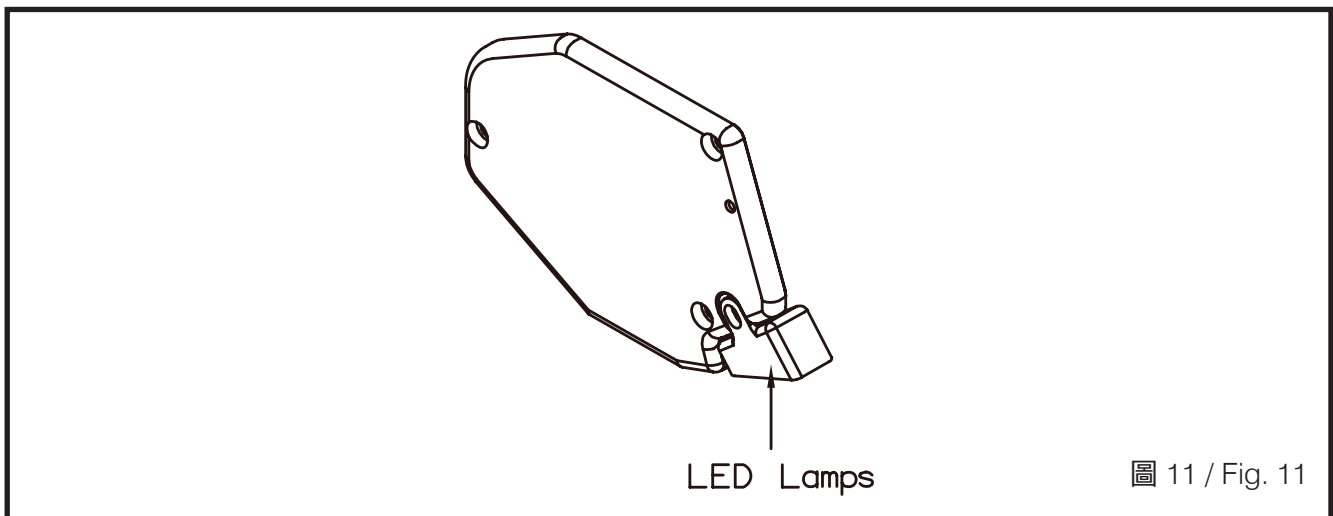
1. Please operate this machine in 80% of the maximum speed in the first four weeks for engagement. After four weeks, please do not operate under the maximum speed until replacing the new lubrication oil.
2. Periodically maintain and clean the machine to ensure and extend the usage term of the machine.

潤滑油之注入與更換

1. 潤滑油之注入(圖 12)
 - (1) 將油鏡(A)旋開，以包裝箱內所附之超高速潤滑油或選用ESSO#32 (或 MOBIL#10)等相當之機油加入，使油量指示桿位於油標上下之間即可，然後再鎖緊油鏡(A)。

LUBRICATION AND DRAINAGE

- 1.Fill the lubrication oil (Fig.12)
 - (1)Remove the oil level inspection lens (A) and fill it with the attached ultra high speed lubricating oil, or choose ESSO#32 (or MOBIL #10)or equivalent. Tighten the oil level inspection lens (A) after the oil level indicator locates between the two marking lines.



圖 12 / Fig. 12

2. 潤滑油之更換 (圖 13)

- (1) 將螺絲①放鬆旋開，使油槽內的油完全排出後再將螺絲①鎖緊。
- (2) 為延長本機器之壽命，請於開始使用後四個星期更換新油，爾後約每四個月更換一次。
- (3) 為延長本機器之壽命，特別裝有濾油器之機構，請在每使用一個月後卸下清洗乾淨，必要時得換新品。

2. Drainage and refill the oil :(Fig. 13)

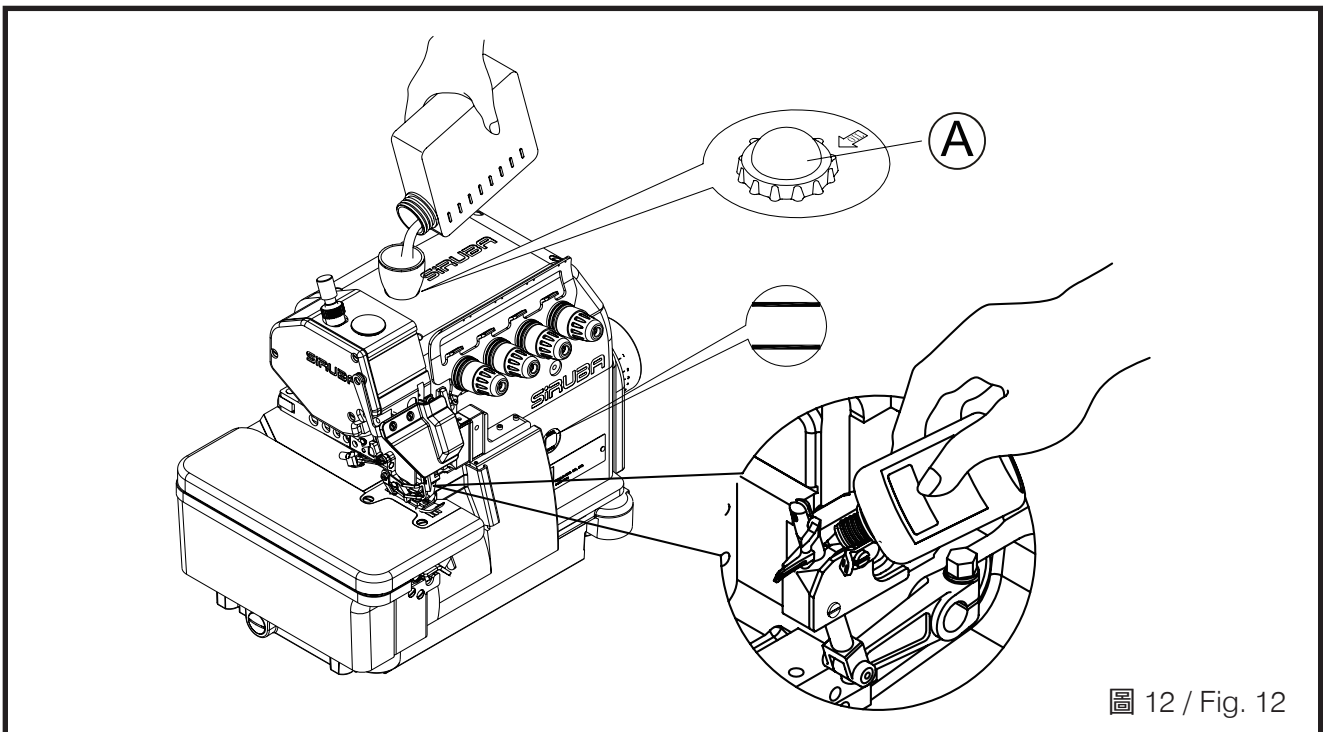
- (1) Loosen the screw ① and drain all the oil inside the oil tank. Then, tighten the screw ① again.
- (2) In order to extend the term of usage, please replace the oil after the first four week, and then replace it every four months.
- (3) To extend the usage term, this machine has equipped an oil filter. Please disassemble and clean it every month, as well as change it if needed.

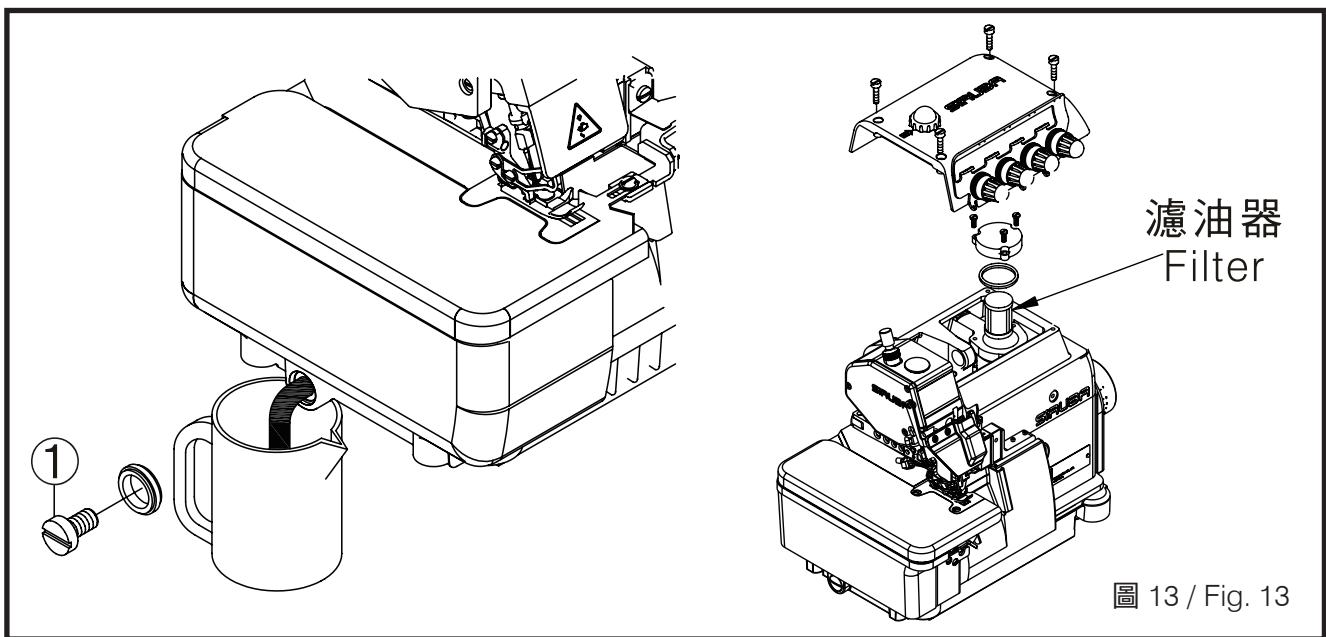

3. 針之冷卻油

使用油：矽油 (SILICON OIL)。(圖 14)

3. Needle cooling lubrication oil:

SILICON OIL. (Fig. 14)

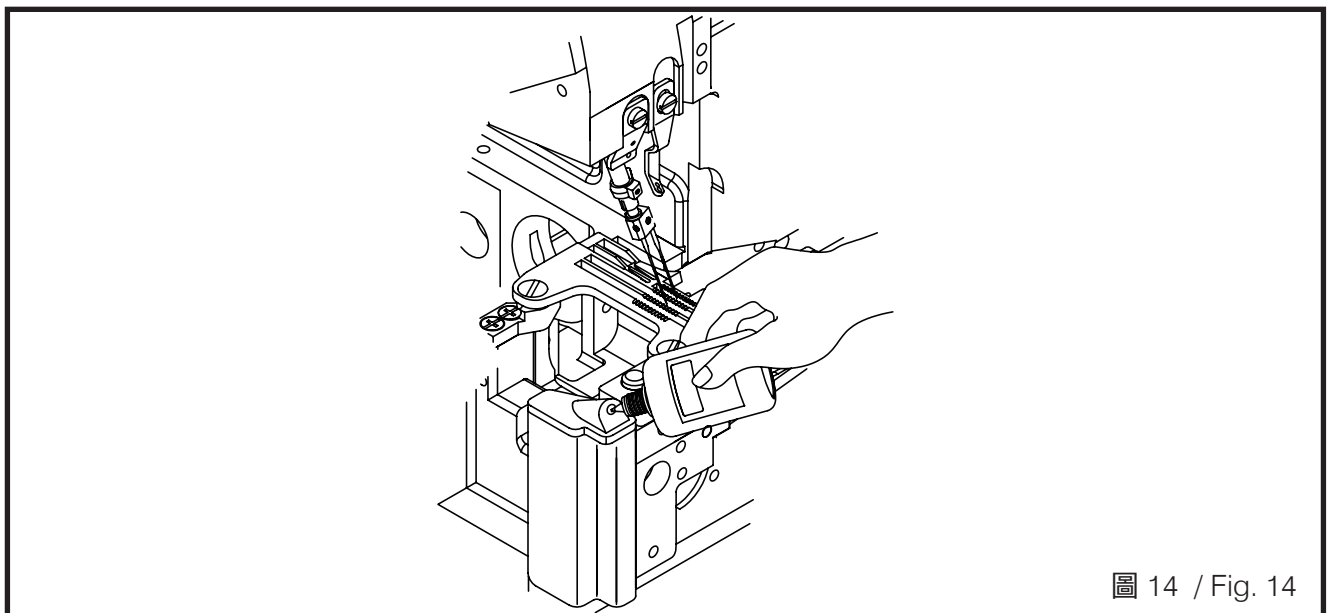

穿線方式

THREADING THE MACHINE

- 請確實按照圖示穿線，錯誤之穿線將引起斷線、跳針或車縫不平……等現象。(圖 15~17)

- Follow the procedures for threading. Wrong threading may cause thread breaking, stitch skipping, puckering or unexpected sewing. (Fig.15~17)

只有三線-637
For Three Thread Only
637



圖 15 / Fig. 15

四線-647
For Four Thread Only
647

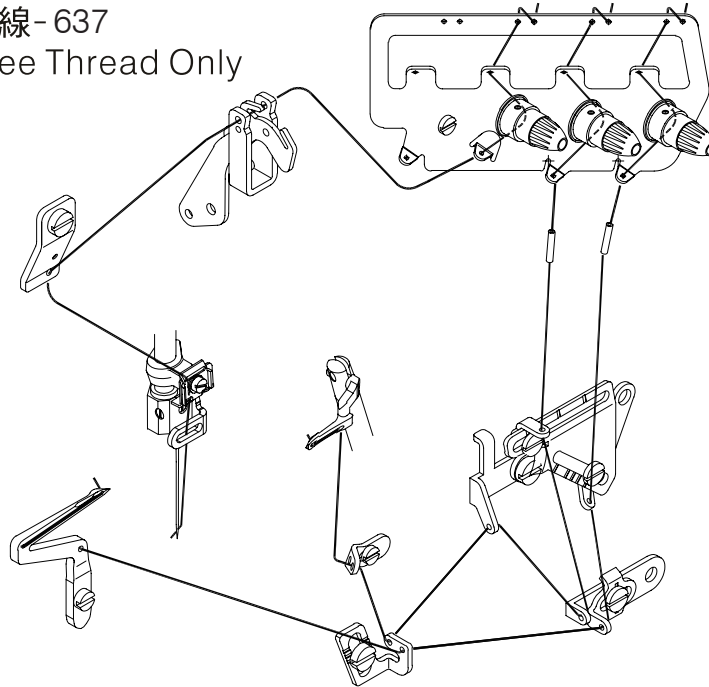

圖 16 / Fig. 16

五線-657
For Five
Thread Only
657

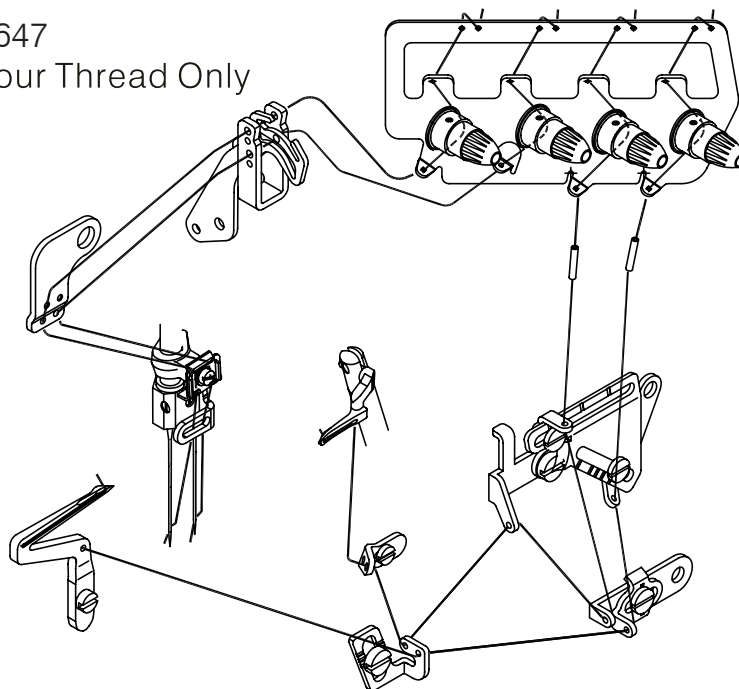

圖 17 / Fig. 17

控線調整

ADJUST THREAD TENSION

線張力必須根據縫合布料種類，布料厚薄，線及包邊寬度等之差異而做不同的調整。順時針旋轉張力控制螺帽，縫線張力加大，反之減弱。

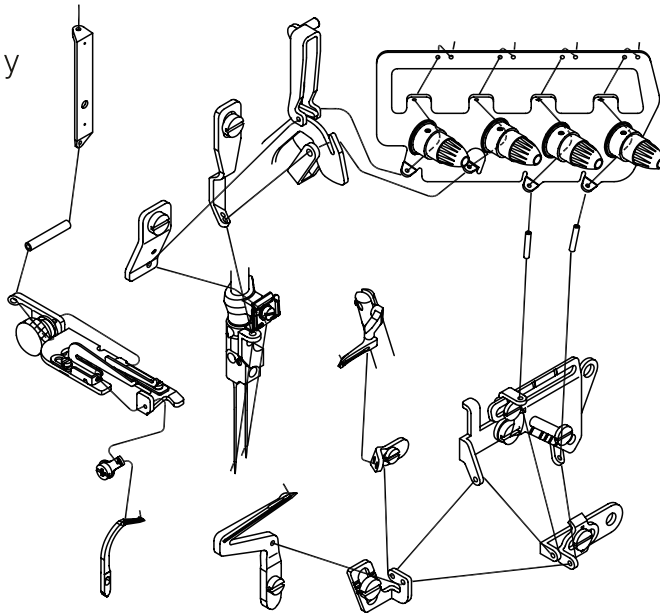
The thread tension should be adjusted properly according to the kinds and the thickness of the materials, stitch length, and seam width, etc. In addition, adjust the nuts case by case individually. Turn the nuts clockwise will increase the thread tension. Otherwise, the thread tension will be decreased.

1. 調整鈕之控線關係。(圖 18)

(1) 調整鈕①控制雙環針線或左邊拷克線。

(2) 調整鈕②控制包邊針線。

(3) 調整鈕③控制上勾針線。

(4) 調整鈕④控制下勾針線。

(5) 調整鈕⑤控制雙環勾針線。

1. Thread tension adjusting nuts. (Fig.18)

(1)The first adjusting knob ① controls double chain stitch threads or the left over-lock needle thread.

(2)The second adjusting knob ② controls the seam lock needle thread.

(3)The third adjusting knob ③ controls the seam lock needle thread.

(4)The fourth adjusting knob ④ controls the lower looper thread.

(5)The fifth adjusting knob ⑤ controls the lower looper thread.



圖 18 / Fig. 18

2. 針線控線關係 (圖 19)

- (1) 縫合方式 504、512、514 時，將過線組件 ① 移至最下端，縫合方式 516 時，則將過線組件 ①、② 移至最上端。
- (2) ⊕ 表示增加針線放線量。
- (3) ⊖ 表示減少針線放線量。

2. Needle thread control. (Fig.19)

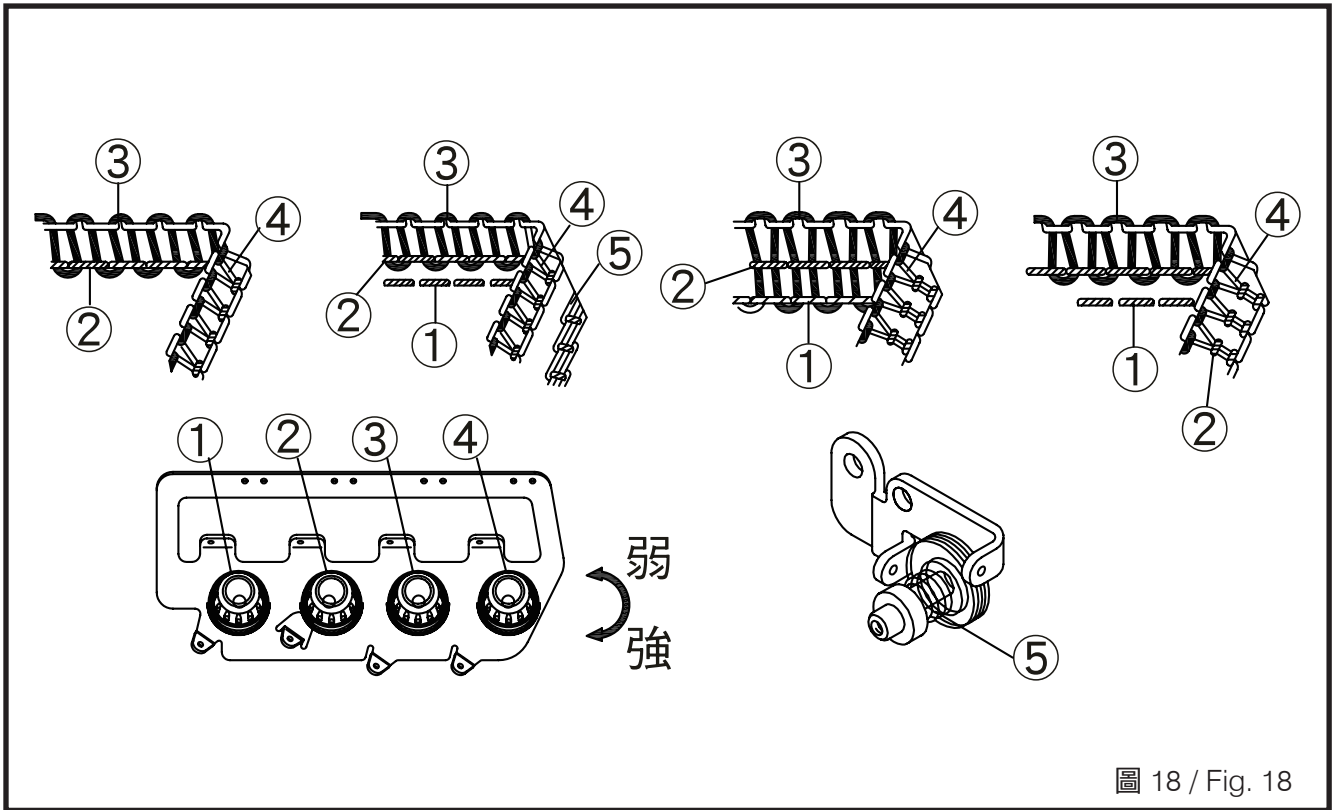
- (1) When the sewing type is set to 504, 512 or 514, move the threading part ① to the lowest part. When the sewing type is 516, move the threading part ① and ② to the highest point.
- (2) The ⊕ direction indicates to increase the length.
- (3) ⊖ means to decrease the needle thread length.



圖 19 / Fig. 19

3. 勾針控線關係 (圖 20)

- (1) 若縫合方式為 504, 505 及上勾針移至最低時，將①及②調至⊕位置。若縫合方式為 505 時，則移至⊖端。
- (2) 固定線導板 ③、④ 如下：
 ⊕ 方向為縫合線較多，⊖ 反之較少。

3. Looper thread control.(Fig. 20)

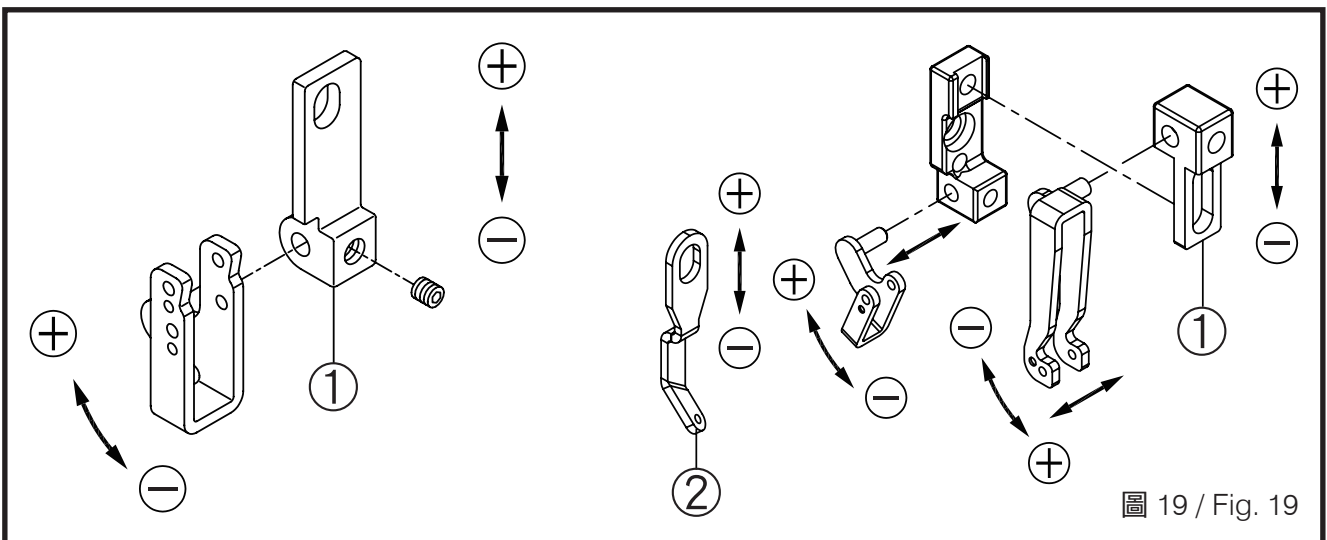
- (1) When the sewing type is 504, 505 and the upper looper is on the lowest point, adjust ① and ② at the position of ⊕ .
 When the sewing type is 505, set the take-up ① and ② at the position of ⊖ .
- (2) Adjust fixed thread guide plate ③ and ④ as the following:
 The direction ⊕ is for more thread in sewing seam, and the ⊖ direction is for less thread in sewing seam.



圖 20 / Fig. 20

4. 環縫線凸輪控線關係 (圖 21)

- (1) 調整底線導致線環不穩定 (鬆塌或成形不足) 時。
- (2) ⊕ 表示增加針線放線量。
- (3) ⊖ 表示減少針線放線量。

4. Chainstitch thread cam control .(Fig.21)

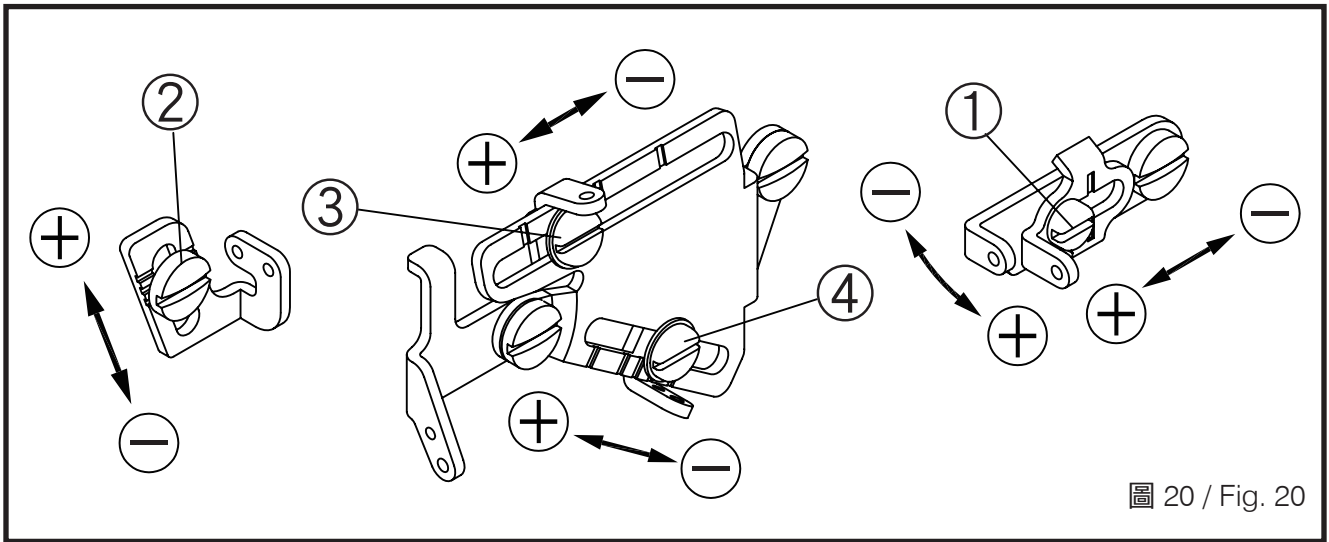
- (1) Adjusting the lower thread causes the thread ring unstable (too loose or didn't form a thread ring).
- (2) ⊕ means to have more thread amount while sewing.
- (3) ⊖ means to have less thread amount while sewing.



圖 21 / Fig.21

換針方式

1. 使用 DCX27 或同規格之針。
2. 旋開螺絲 ① 並取下針。
3. 將新針插至針孔最底端，並使針之溝面向自己，固定螺絲 ①。(圖 22)

REPLACE THE NEEDLE

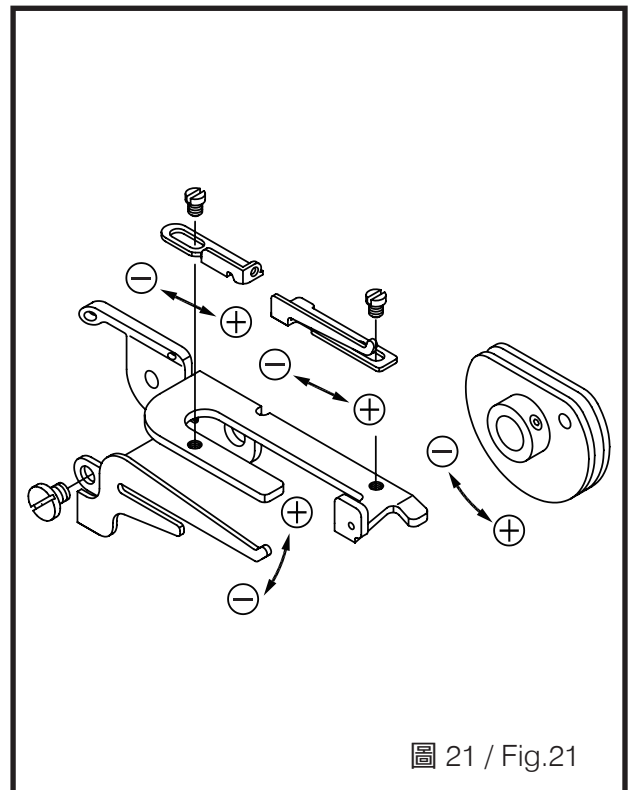
1. Please use the needle DCX27 or the equivalents.
2. Loosen the screw ① and take off the needle.
3. Insert the new needle till reaching the end, as well as the long groove faces your side. Tighten the screw ①. (Fig.22)



圖 22 / Fig.22

針距調整

- 通常依據車縫布料，差動比等之不同而調整。持續壓下按鈕 ① 並轉動手輪使按鈕卡住，再轉動手輪至所需之針距後放開此按鈕。(圖 23)(表 3)

ADJUST THE STITCH LENGTH

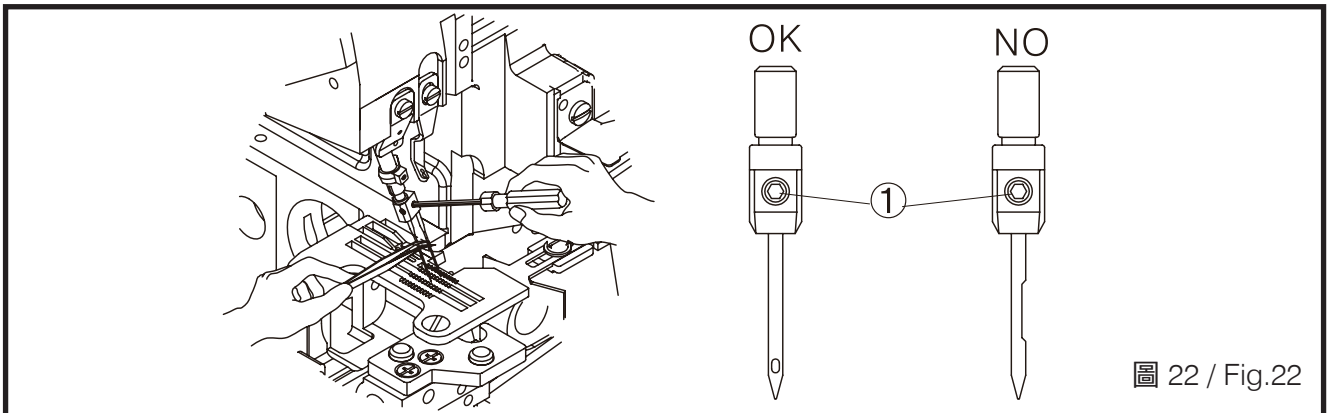
- The stitch length is adjusted according to the fabrics, the differential ratio or other factors. Keep pressing the button ① and turn the pulley till the button is locked. Then, release the button after reaching the desired stitch length.(Fig.23)(Tab.3)

最大差動比 Maxi Diff ratio	機種 Machine type	皮帶輪刻度 Pulley scale						
		1	2	3	4	5	6	7
1:2	接縫 Seaming	0.6	1.13	1.66	2.19	2.72	3.25	3.8
1:3	摺縫 Shirring	0.6	1.03	1.46	1.89	2.32	2.71	3.2
1:1.3	包邊 Serging	0.8	1.5	2.2	2.9	3.6	4.3	5
1:4	特規 Special	0.6	1.02	1.44	1.66	2.28	2.7	-

表 3 / Tab.3



圖 23 / Fig.23

差動比調整

ADJUST THE DIFFERENTIAL FEED RATIO

若主送具之運動行程大於差動送具運動行程時，布料車縫時會伸張，反之則會收縮。

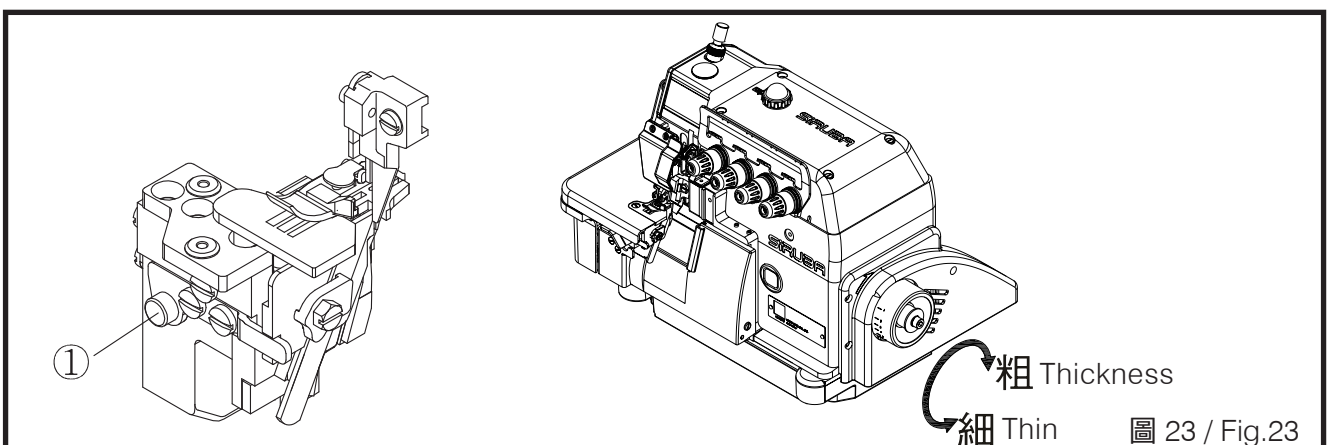
If the stroke of the main feed dog is larger than the stroke of the differential feed dog, the fabric will be extended while sewing. Otherwise, it will be shrunk.

1. 調整方法一：

為放鬆調整鈕 ①，當調整桿 ② 向下調整時使布料收縮，反之則伸張，調整後再鎖調整鈕 ①。(圖 24)(表 4)

1.Adjust solution 1:

Loosen the adjusting nut ①. Adjust the adjusting rod ② downward will shrink the fabric, whereas move it upward will extend the fabric. Tighten the adjusting nut ① after the adjustment finishes. (Fig.24)(Tab.4)

刻度 Scale		1	2	3	4	5
差動傳送比 Differential feed ratio	1:1.3	-	1:0.7	1:0.9	1:1.1	1:1.3
	1:2	1:0.7	1:1	1:1.14	1:1.17	1:2
	1:3	1:1	1:1.5	1:2	1:2.5	1:3
	1:4	1:1.1	1:1.6	1:2.3	1:2.3	1:3.3

表 4/ Tab.4



圖 24 / Fig. 24

2. 調整方法二：

- (1) 鬆開螺絲 ③ 並從機台後方移開外蓋 ④。
- (2) 鬆開螺帽 ⑤，上下移動連桿 ⑥
欲增加差動比，把連桿⑥往 (+) 方向移動
欲減少差動比，把連桿⑥往 (-) 方向移動。
- (3) 在調整過後，把外蓋 ④ 放回機台後方並鎖回螺絲③。(圖 25)

2.Adjust solution 2:

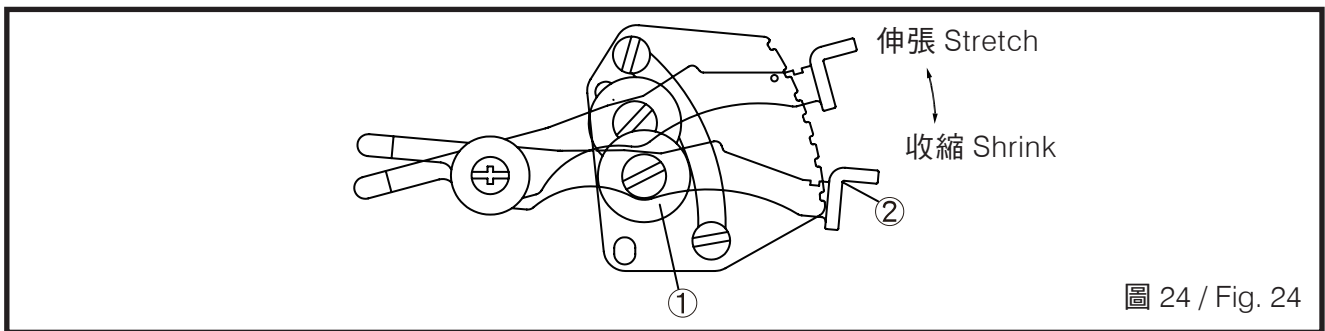
- (1) Loosen the screw ③ and remove the cover ④ from the rear side of the machine bed.
- (2) Loosen the nut ⑤, and move the connecting rod ⑥ upward and downward. To increase the differential feed ratio, move the connecting rod ⑥ to (+) direction. To decrease it, move the connecting rod ⑥ to (-).
- (3) After adjusting, put the cover ④ back to the rear of the machine bed and tighten the screw ③.(Fig.25)



圖 25 / Fig. 25

更換切刀

1. 更換上切刀 (圖 26)

- (1) 放鬆螺絲①將下刀座②向左邊推，輕鎖螺絲①。
- (2) 取下螺絲③換上新刀片後，輕輕鎖緊螺絲③。
- (3) 轉動皮帶輪使上刀移至下死點，調整上刀高低使上刀與下刀相交約 0.5~1.0mm，鎖緊螺絲③。
- (4) 放鬆螺絲①使下刀座還原位置，並試驗上下刀能確實剪斷車縫線，鎖緊螺絲①。

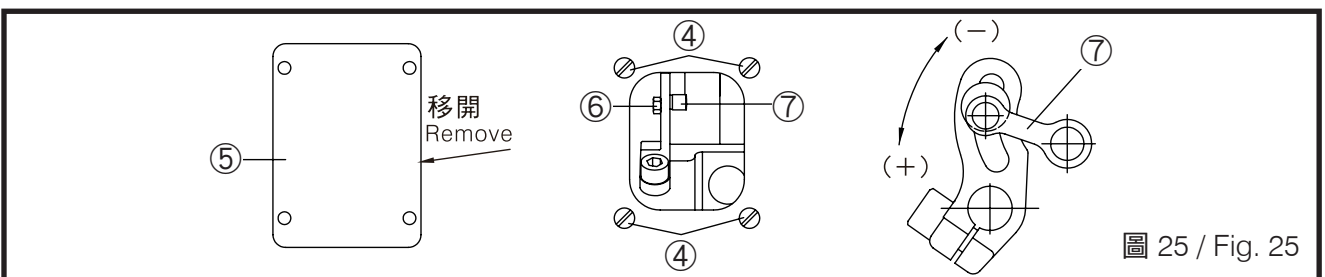
2. 更換下切刀 (圖 26)

- (1) 放鬆螺絲①將下刀座②向左邊推，輕鎖螺絲。
- (2) 放鬆螺絲④取下舊刀換上新刀。
- (3) 調整下刀之刀口與針板面平齊後，鎖緊螺絲④。
- (4) 放鬆螺絲①，使下刀座還原位置，並試驗上下刀能確實剪斷車縫線，鎖緊螺絲①。

REPLACE THE TRIMMERS

1. Replace the upper trimmer (Fig. 26)

- (1) Loosen the screw ① and move the lower trimmer holder ② to the left. Then, tighten the screw ① a little.
- (2) Remove the screw ③ and put the new trimmer. Then, tighten the screw ③ a little.
- (3) Turn the pulley to move the upper trimmer to the lower dead point. Adjust the height of the upper trimmer so that the upper trimmer can cross the lower trimmer about 0.5 ~ 1.0 mm. After that, tighten the screw ③.
- (4) Loosen the screw ① and return the lower trimmer to its original position. Test if the upper and the lower trimmer can cut the thread exactly, and then tighten the screw ①.

2. Replace the lower trimmer (Fig. 26)

- (1) Loosen the screw ① and move the lower trimmer holder ② to the left. Then, tighten the screw ① a little.
- (2) Loosen the screw ④. Take off the trimmer and replace a new one.
- (3) Adjust the edge of the lower trimmer to be align with the surface of the needle plate. Then, tighten the screw ④.
- (4) Loosen the screw ① to return the lower trimmer holder to its original position and test if the upper and the lower trimmer can cut the thread exactly. Then, tighten the screw ①.



圖 26 / Fig. 26

包邊寬度調整

ADJUST THE HEM WIDTH

1. 轉動手輪，將上刀移至下死點。(圖 27)
2. 放鬆螺絲①，向左移動下刀座疊②後，暫時輕鎖螺絲①。
3. 放鬆螺絲③，移動上刀座向左或向右，直到達到所要的包邊寬度後再鎖緊螺絲③。
4. 放鬆螺絲①，使下刀座②位置還原，並測試能切斷車縫線後，鎖緊螺絲①。

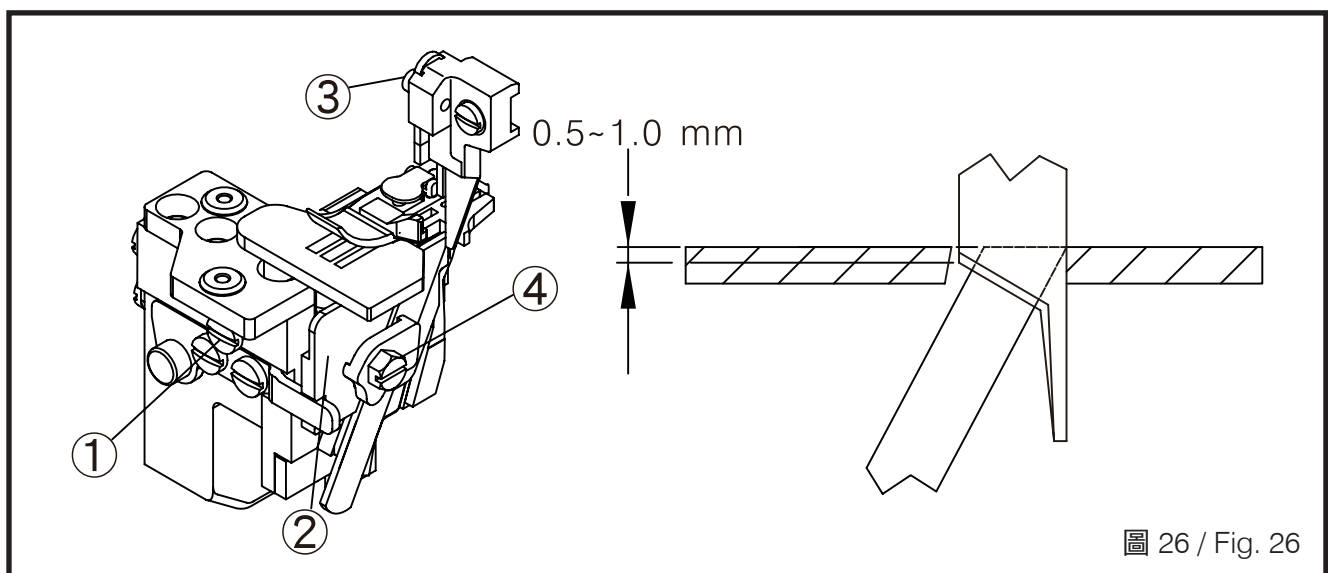
1. Turn the pulley to move the upper trimmer to the lower dead point. (Fig.27)
2. Loosen the screw ① and move the lower trimmer holder ② to the left, and then tighten the screw ① a little.
3. Loosen the screw ③ and move the upper trimmer holder ② left or right till reaching the desired width. Then, tighten the screw ③.
4. Loosen the screw ① to return the lower trimmer holder ② to its original position. Test if the trimmers can cut the thread, and then tighten the screw ①.



圖 27 / Fig. 27

針高度之調整

ADJUST THE NEEDLE HEIGHT

1. 轉動手輪使針上昇至最高點時，針尖至針板面之距離為 (a)。(圖 28)
2. 調整：
 - (1) 打開上蓋③。
 - (2) 放鬆螺絲④，移動針棒至所需高度鎖緊螺絲④。
 - (3) 放回上蓋③須密合鎖緊。

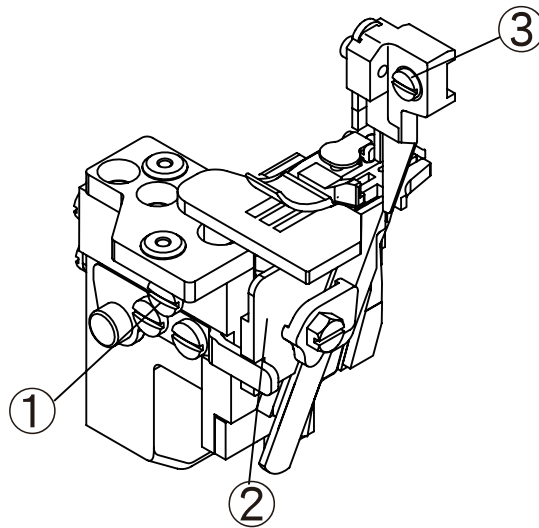
1. The (a) is the distance from the needle tip to the surface of the needle plate when the needle is risen to the highest point after turning the pulley.(Fig.28)
2. Adjustments:
 - (1) Open and remove the upper cover ③ .
 - (2) Loosen the screw ④, and move the needle bar to the desired height. Then, tighten the screw ④ .
 - (3) Put the upper cover ③ back, and seal it.



圖 28/ Fig. 28

押具調整

ADJUST THE PRESSER FOOT

1. 押具位置調整 (圖 29)
 - (1) 放鬆押具壓力①及押具螺絲⑦。
 - (2) 移動押具⑥使其押具槽與針板之針槽一致押具底平壓於針板上，鎖緊螺絲⑦。
 - (3) 放鬆螺絲⑤左右移動④，使③與②吻合，且②能上下活動輕順，鎖緊螺絲⑤。
 - (4) 調整適當壓力，螺絲①順時針方向旋轉，壓力加大，反之減弱。

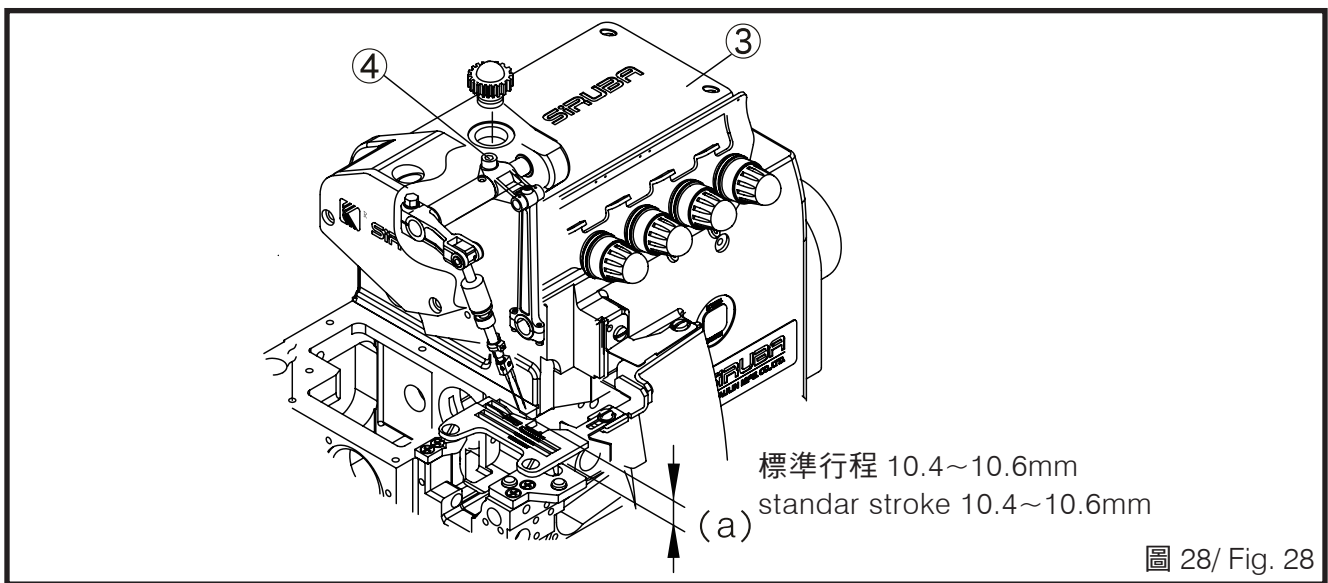
1. Adjust the presser foot position.(Fig.29)
 - (1) Release the pressure spring ① of the presser foot and the screw ⑦ of the presser foot.
 - (2) Move the presser foot ⑥ so that the groove of the presser foot can align with the groove of the needle plate. Also, the bottom of the presser foot can stand on the needle plate flatly, and then tighten the screw ⑦ .
 - (3) Loosen the screw ⑤ , and move ④ left and right so that ③ can match ② and ② can move upward and downward smoothly. Then, tighten the screw ⑤ .
 - (4) To adjust to a proper pressure: turn the screw ① clockwise will increase the pressure, where as turn it counter clockwise will decrease the pressure.



圖 29 / Fig. 29

2. 押具提升量調整 (圖 30)

- (1) 轉動皮帶輪使送具降至針板下，押具底平貼針板。
- (2) 放鬆螺帽④，壓下拉桿⑥使押具上昇至適當位置約 5.0~5.5mm，調整螺絲⑤及固定螺帽④。
- (3) 拉桿①與固定座②須保持有 1mm 的間隙可輕輕放鬆螺絲③調整。
- (4) 要確實鎖緊螺絲③。

2. Adjust the lift amount of the presser foot. (Fig.30)

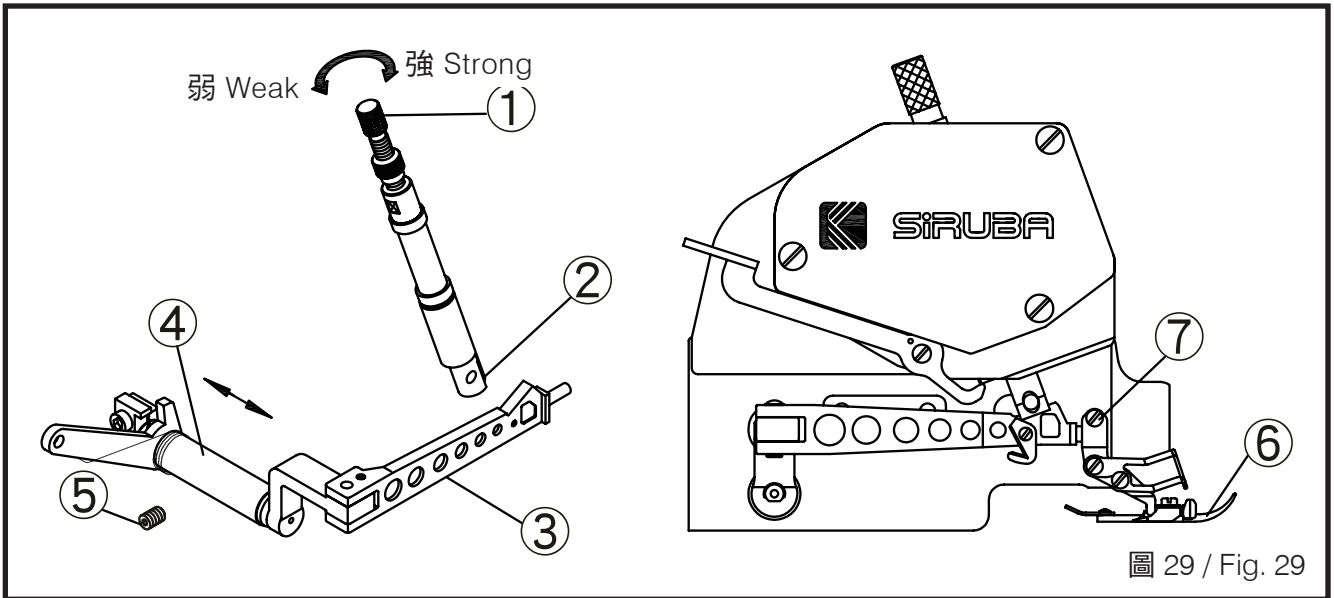
- (1) Rotate the pulley to move the feed dog downward until the feed dog is under the needle plate, as well as the bottom of the presser foot touches the needle plate flatly.
- (2) Loosen the nut ④, and press the pull rod ⑥ in order to rise the presser foot 5.0 ~5.5mm. Then, adjust the screw ⑤ and tighten the nut ④.
- (3) There should be a clearance of 1mm between the pull rod ① and the fixed bracket ②, which can be adjusted by loosening the screw ③ slightly.
- (4) After all the adjustments above, please tighten the screw ③.



圖 30 / Fig. 30

送具調整

ADJUST THE FEED DOG

1. 送具高度調整 (圖 31)

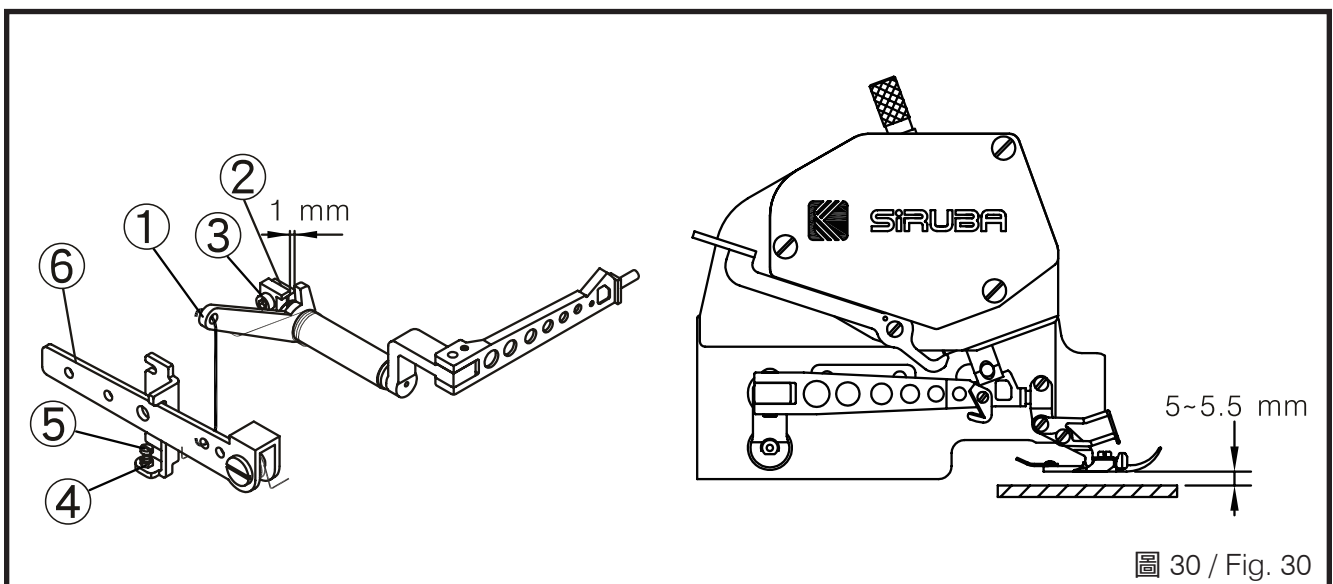
- (1) 轉動皮帶輪使送具上升至針板上最高點。
- (2) 放鬆螺絲①，上下移動主送具②，使其齒面高出針板面約 0.9~1.1mm，鎖緊螺絲①。
- (3) 放鬆螺絲③，上下移動差動送具④，使其齒面高出針板面約 0.9~1.1mm 鎖緊螺絲③。

1. Adjust the feed dog height (Fig.31)

- (1) Rotate the pulley to rise the feed dog the highest point of the needle plate.
- (2) Loosen the screw ①, and move the main feed dog ② up and down in order to keep the teeth side over the needle plate about 0.9~1.1mm. Then tighten the screw ①.
- (3) Loosen the screw ③, and move the differential feed dog ④ up and down in order to keep the teeth side over the needle plate about 0.9~1.1mm. Then, tighten the screw ③.

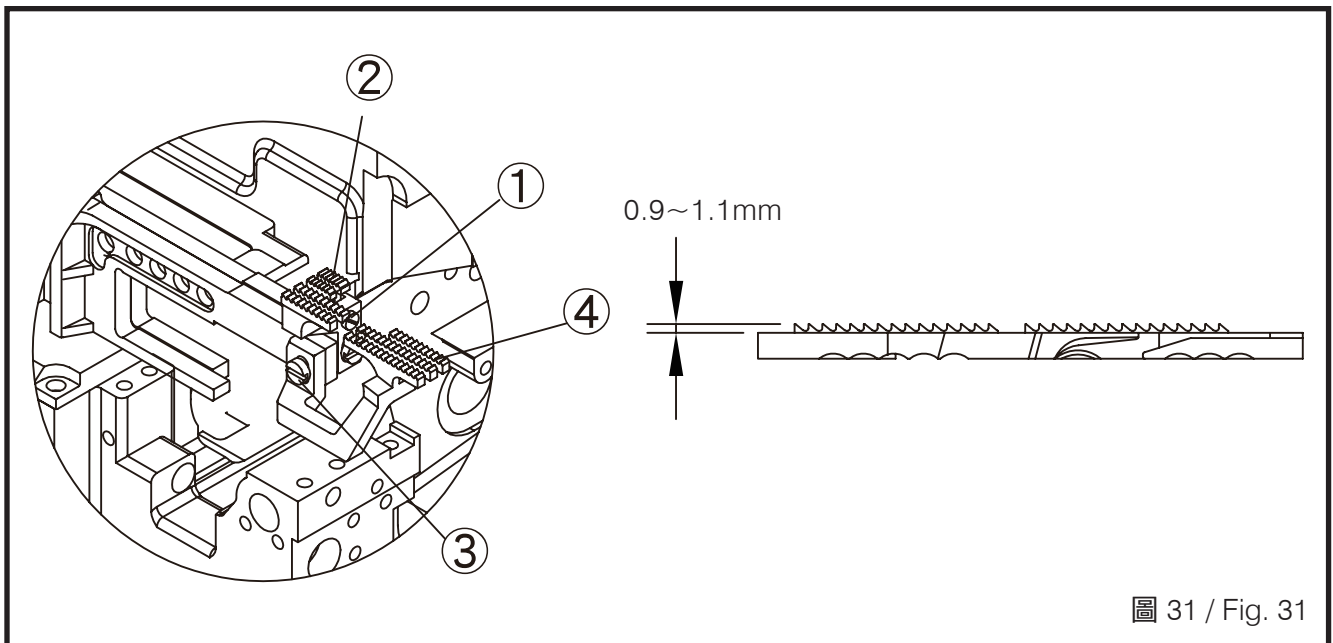

2. 送具水平調整 (圖 32)

- (1) 送具齒的齒面在運轉的循環中，必須保持針板面成水平。
- (2) 調整時放鬆螺絲①，旋轉後支軸②，齒面呈水平後固定螺絲①。

2. Adjust the feed dog horizontally (Fig. 32)

- (1) During operation, the teeth side of the feed dog should keep parallel with the surface of the needle plate.
- (2) For adjustment, loosen the screw ①, and rotate the rear support shaft ②. Do not tighten the screw ① until the teeth side of the feed dog is horizontal.



圖 32/ Fig. 32

3. 輔助送布齒高度 (圖 33)

輔助送具①，其齒面比送布齒齒面低 0.3~0.5mm，可放鬆螺絲②來調整。

3. Adjust the auxiliary feed dog height (Fig.33)

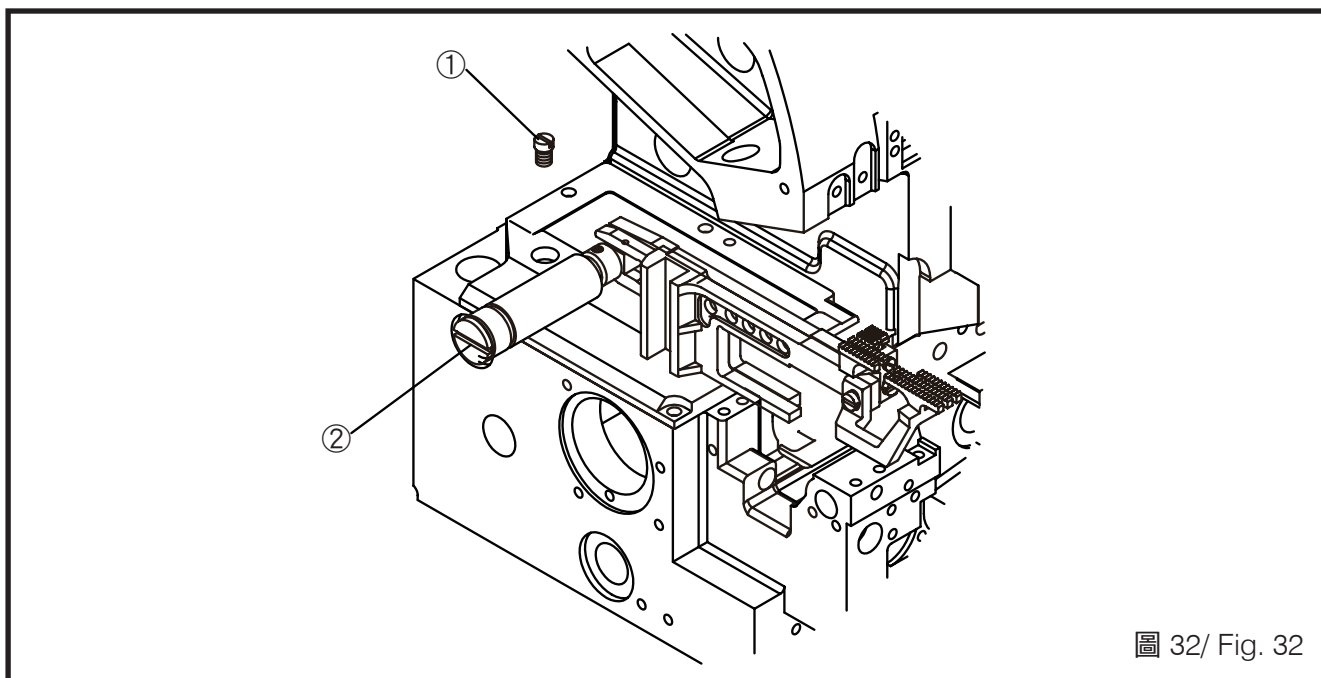
The teeth side of the auxiliary feed dog ① is 0.3~0.5mm lower than the feed dog. The height can be adjusted by loosening the screw ②.



圖 33/ Fig. 33

針與勾針之關係

THE RELATIONSHIP BETWEEN NEEDLE AND LOOPER

1. 針與上勾針之關係 (圖 34)
當上勾針移至最左時，勾針尖端與針中心距約 4.4 ~ 4.7mm，雙針時其左針中心與勾針尖端距約 5.4~5.7mm。

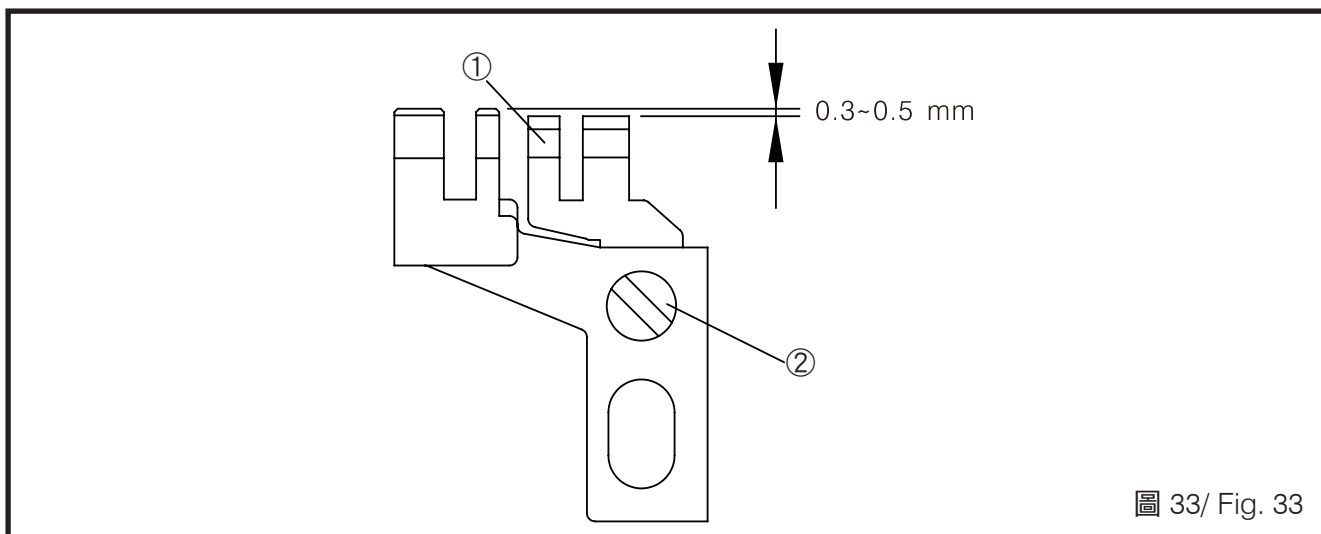
- 1.The relationship between the needle and the upper looper.(Fig.34)
When the upper looper moves to the leftest point, the distance from the looper tip to the middle line of the needle is 4.4 ~ 4.7mm. For double needles model, the distance from the looper tip to the middle line of the left needle is 5.4~5.7mm.

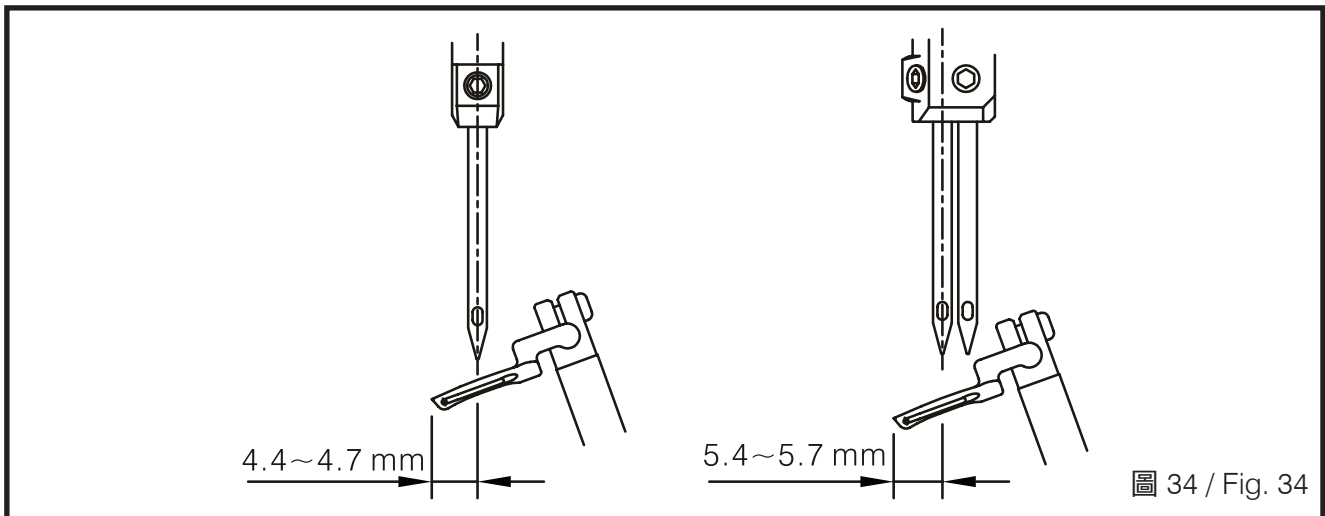

2. 針與下勾針之關係
(1) 當下勾針移至最左時，勾針尖端與針中心距約 3.7~3.9mm(雙針時以左針為主)。(圖 35)

- 2.The relationship between the needle and the lower looper.
(1)When the lower looper moves to the leftest point, the distance between the looper tip and the middle line of the needle should be about 3.7~3.9mm. For double needles model, the distance is from the lower looper tip to the middle line of the left needle. (Fig.35)

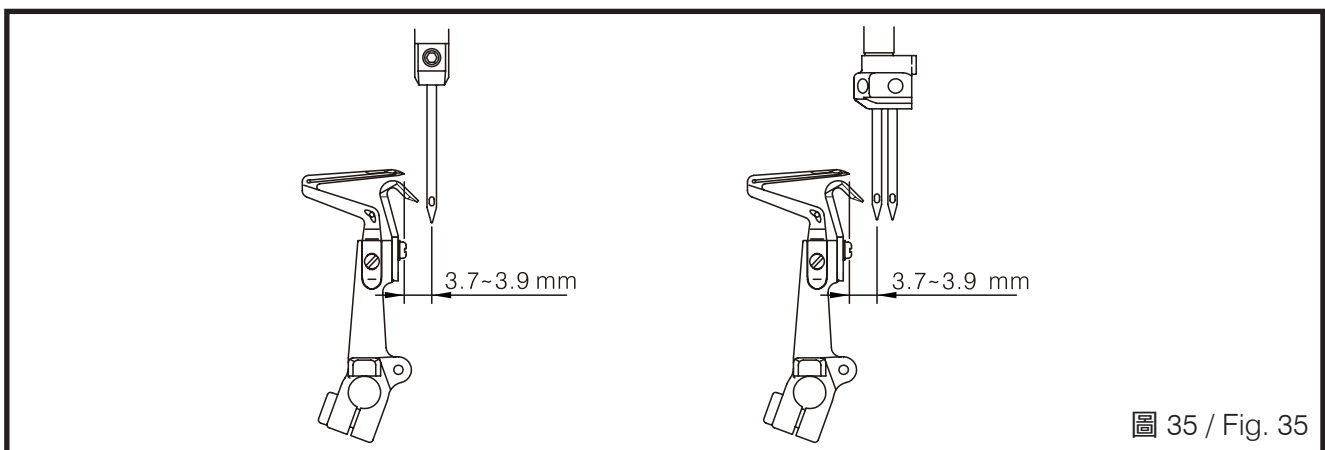

- (2) 當下勾針向右移至針中心時 (雙針以左針為主) 針與勾針之間隙為 $0 \sim 0.05\text{mm}$ 。
(圖 36)

- (2) The relationship between the needle and the middle line of the needle (use the left needle as standard when it's double needle model), the clearance between them should be $0 \sim 0.05\text{mm}$. (Fig.36)

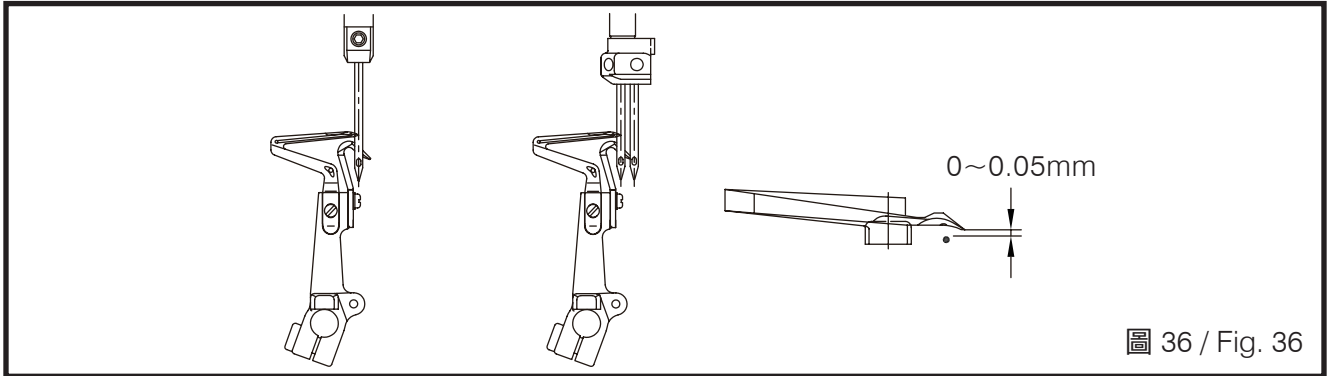

3. 上勾針與下勾針之關係 (圖 37)
當上下勾針相交時，兩勾針盡量接近，但不可磨擦或碰撞，其間隙 A 點為 $0.35 \sim 0.65\text{mm}$ ，B 點為 $0.1 \sim 0.3\text{mm}$ 。

3. The relationship between the upper looper and the lower looper. (Fig.37)
When the upper and the lower looper cross, keep them as close as possible. Somehow, the loopers shall not either touch or collide to each other. The clearance point A is $0.35 \sim 0.65\text{mm}$, as well as the clearance point B is $0.1 \sim 0.3\text{mm}$.

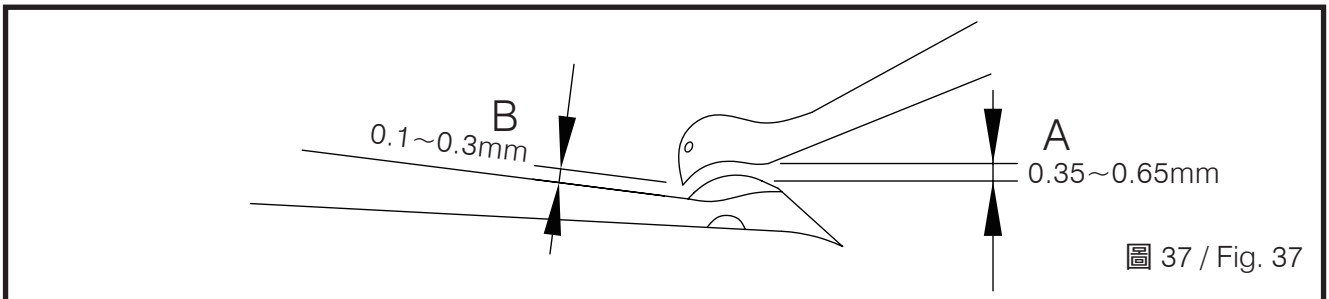

4. 針與環縫勾針之關係 (圖 38)
當環縫勾針移至最左時，勾針尖端與針之中心距離為 $1.6 \sim 2.3\text{mm}$ 。

4. The relationship between the needle and the chainstitch looper. (Fig.38)
When the chainstitch looper moves to the leftest point, the distance from the chainstitch looper pin to the middle line of the needle is $1.6 \sim 2.3\text{mm}$.

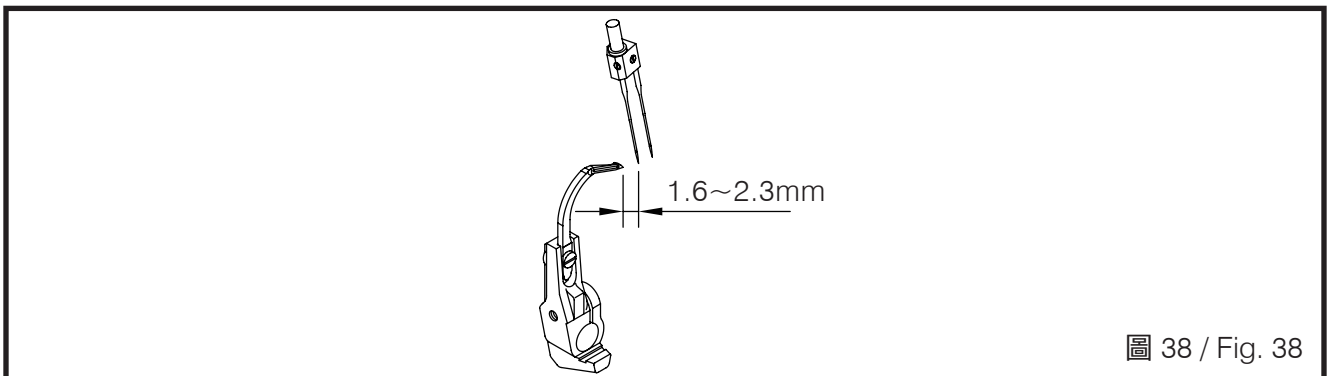

5. 針與檔針片之關係 (圖 39)

(1) 當下勾針由左向右至針中心時 (雙針以左針為主) 針與後檔針片之間隙為 $0 \sim 0.05\text{mm}$ 。

(2) 當針在下死點時，針與前檔針片之間隙為 $0.1 \sim 0.2\text{mm}$ 。

5. The relationship between the needle and the needle guard. (Fig.39)

(1) When the lower looper moves from left to right to the central line of the needle (when it's double needle model, it means the left needle), the clearance from the needle to the rear needle guard is $0 \sim 0.05\text{mm}$.

(2) When the needle is at the lower dead point, the clearance between the needle and the front needle guard is $0.1 \sim 0.2\text{mm}$.



圖 39 / Fig. 39

環勾針運動量之調整

ADJUST THE CHAINSTITCH LOOPER MOVEMENT AMOUNT

環勾針之運動呈橢圓形，當針號數變動過大時或有必要調整環勾針之前後運動量 a 時，請依照以下步驟調整。(圖 40)

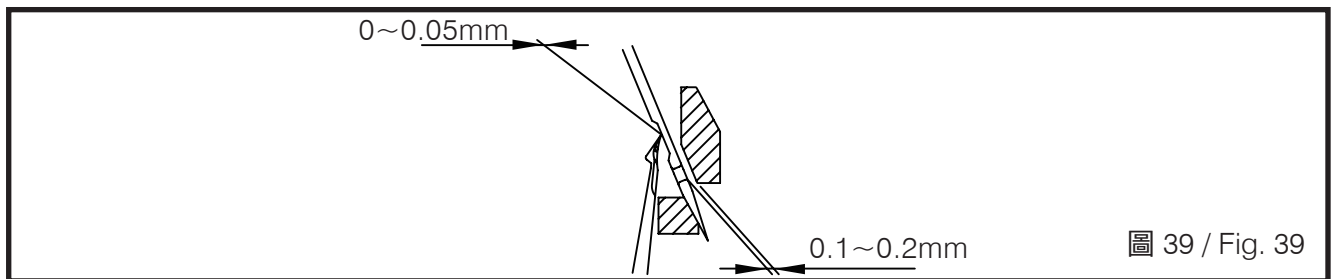
1. 打開縫紉機背面的封蓋 ①。
2. 輕輕放鬆螺絲 ③。
3. 旋轉調整螺絲 ②，
向 \oplus 方向加大前後運動量。
向 \ominus 方向減少前後運動量。
4. 調整後鎖緊螺絲 ③。
5. 鎖緊封蓋 ①。

The movement of the chainstitch looper is oblong shape. When the difference of the changed needle number is too large, or if necessary to adjust the front/rear movement amount a of the chainstitch looper, please follow the steps below to adjust. (Fig.40)

1. Open the sealed cover ① in the back side of the machine.
2. Loosen the screw ③ slightly.
3. Turn the screw ② to adjust. To increase the movement amount, turn to \oplus direction. To decrease the movement amount, turn to \ominus direction.
4. Tighten the screw ③ after the adjustment.
5. Then, seal the cover ①.



圖 40 / Fig. 40



注意CAUTION

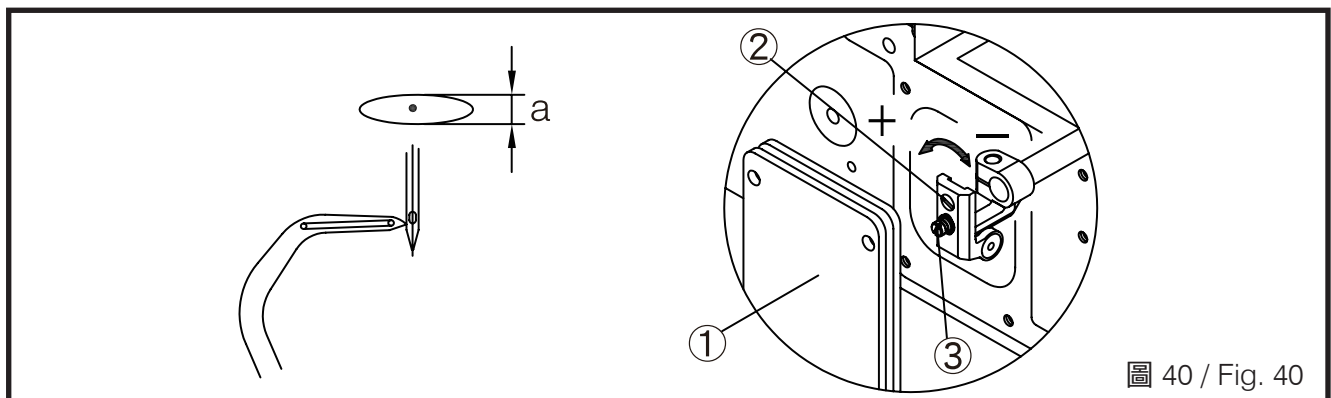

清潔作業前，請切斷電源。當誤觸起動開關時，縫紉機動作易導致人員受傷。
Turn off the power switch before carrying out cleaning. The machine may operate if the treadle is pressed incautiously, which could result in injury.



加潤滑油和黃油時，務必戴好保護眼鏡和手套，以防潤滑油進入眼中或沾在皮膚上，易引起發炎。

Be sure to wear protective goggles and gloves when handling the lubricating oil and grease so that they do not get into your eyes or onto your skin, otherwise inflammation can be resulted.



潤滑油或黃油不能飲用，否則將會引起嘔吐和腹瀉，將油放在小孩拿不到的地方。
Furthermore, do not drink or eat the oil nor the grease for they can cause vomiting and diarrhea. Keep the oil away of the reach of children.

縫紉機頭倒下或豎起時，請以雙手進行操作。

Use both hands to hold the machine head when tilting or returning it to its original position.



單手操作時，因縫紉機的重量較重，萬一滑落易導致受傷。

If only using one hand to move the machine, the weight of the machine head may cause slipping and you may get hurt.

《定期保養項目》(表6)

《Periodical Maintenance Items》(Table 6)

保養循環 Maintenance Cycle	保養項目 Maintenance Items
每天 Daily	1. 清潔送料具上之棉絮 1. Clean the lint on the feed dog.
	2. 檢查油盤是否有足夠之液態油。(油量在油鏡之上、下兩紅漆記號間) 2. Check if there has enough liquid oil inside the oil pan. (The amount should be between the red up and down paint mark of the oil level gauge.)
	3. 保持機器及操作台清潔 3. Keep the machine and the operation table clean.
每週 Weekly	1. 保持電源外觀乾淨 1. Keep the power cords looking clean and neat.
	2. 保持操作面板乾淨 2. Keep the operational panel clean
	3. 檢查電源零件是否鬆脫或在正確位置 3. Check if the power parts is loosening or still at the right position
每三個月 Quarterly	1. 更換油盤內之液態油 1. Change the liquid oil inside the oil pan
每年 Annually	1. 檢查傳動皮帶是否疲乏或毀損 1. Check the transmission belt to see if it is weariful or damaged.

表 5 / Table 5

報廢流程

DEMOLITION PROCEDURE

1. 當機器需要被淘汰與報廢時，有一些基本規則必須採納、遵守以保護環境及公眾健康。
2. 所有的機器零組件必須依照下列分類來區分開：
 - (1) 所有護套、可伸縮軟管及塑膠或非金屬零件。
 - (2) 電器零件：開關、照明器具等。
 - (3) 絕緣材料：石棉、彈性／可伸縮橡膠片。
 - (4) 金屬：含鐵金屬、銅、青銅與黃銅、其他各種金屬。
3. 以此方法，所有材質可以正確的淘汰，回收再利用或鎔解為可再使用或再處理而不至於危害環境。

1. When the machine needs to be eliminated and demolished, certain basic rules must be observed to protect the environment and public health.
2. All machine components must be divided according to categories as the followings:
 - (1) All sheathes, flexible hosing and plastic or non-metal components.
 - (2) Electricity components: switches, or lighting components.
 - (3) Insulation materials: rock wool, and flexible rubber strips.
 - (4) Metals: ferrous metals, copper, bronze and brass, various.
3. In this way, all materials can be eliminated correctly, recycled, or melted down for reuse or disposed of so that they do not harm the environment.

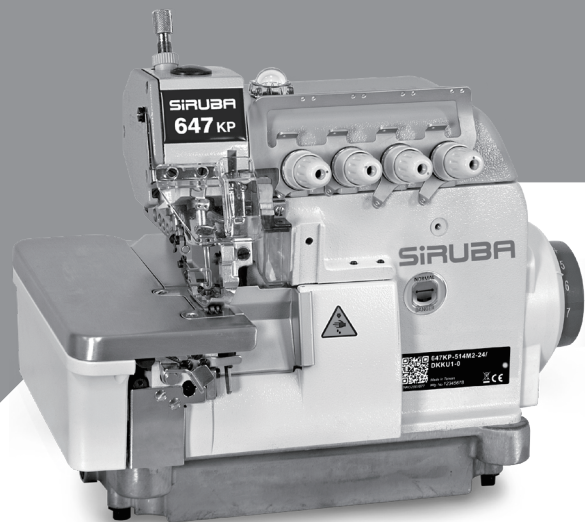

高林股份有限公司
KAULIN MFG. CO., LTD.

由於對產品的改良及更新，本產品使用說明書中與零件圖之產品及外觀的修改恕不事先通知！
The specification and/or appearances of the equipment described in this instruction book & parts list are subject to change because of modification which will without previous notice.
KZ08P.OCT.2021